



Journal and Proceedings
of the
Royal Society
of
New South Wales

Volume 147 Part 2

Numbers 453 and 454

“... for the encouragement of studies and investigations in Science Art Literature and Philosophy ...”

THE ROYAL SOCIETY OF NEW SOUTH WALES

OFFICE BEARERS FOR 2014-2015

Patrons	His Excellency General The Honourable David Hurley AC DSC (Ret'd) Governor of New South Wales
President	Dr Donald Hector BE(Chem) PhD (Syd) FIChemE FIEAust FAICD FRSN
Vice Presidents	Mr John Hardie BSc (Syd), FGS, MACE FRSN Em. Prof. David Brynn Hibbert BSc PhD (Lond) CChem FRSC RACI FRSN Em. Prof. Heinrich Hora DipPhys Dr.rer.nat DSc FAIP FInstP CPhys FRSN
Hon. Secretary (Ed.)	Prof. Michael Burton BA MA MMaths (Cantab) PhD (Edinb) FASA FAIP FRSN
Hon. Secretary (Gen.)	Mr Colin Bradley BBus MA (Bus Res) MHA GAICD
Hon. Treasurer	Mr Shakti Ram BComm (Macq) MBA (Deakin) CPA GAICD
Hon. Librarian	<Vacant>
Councillors	Dr Erik W. Aslaksen MSc PhD FRSN Prof. Richard Banati MD PhD FRSN Mr David Beale BSc(Tech) (UNSW) FIEAust Dr Ragbir Bhathal PhD FSAAS Margaret Cameron LLB (Syd) Mr Brendon Hyde BE (Syd) MEngSc(NSW) MICE (Lon) FIEPak FIEAust CPEng Em. Prof Roy MacLeod AB (Harv) PhD, LittD (Cantab) FSA FAHA FASSA FRHistS FRSN Dr Frederick Osman BSc (Hons) PhD (UWS) Grad Dip Ed FACE MAIP MRSN Judith Wheeldon AM, BS (Wis) MEd (Syd) FACE FRSN
Southern Highlands Branch Rep.	Mr Hub Regtop
Executive Office	The Association Specialists

EDITORIAL BOARD

Prof. Michael Burton BA MA MMaths (Cantab) PhD (Edinb) FASA FAIP FRSN – Hon. Editor
Dr David Branagan MSc PhD(Syd) DSc (Hon) (Syd) FGS
Dr Donald Hector BE(Chem) PhD (Syd) FIChemE FIEAust FAICD
Prof. David Brynn Hibbert BSc PhD (Lond) CChem FRSC RACI FRSN
Dr Michael Lake BSc (Syd) PhD (Syd)
Dr Nick Lomb BSc (Syd) PhD (Syd) FASA FRSA
Prof. Bruce Warren MB BS (Syd) MA DPhil DSc (Oxon) FRCPATH FRSN

The Society traces its origin to the *Philosophical Society of Australasia* founded in Sydney in 1821. The Society exists for “*the encouragement of studies and investigations in Science Art Literature and Philosophy*”: publishing results of scientific investigations in its Journal and Proceedings; conducting monthly meetings; awarding prizes and medals; and by liaison with other learned societies within Australia and internationally. Membership is open to any person whose application is acceptable to the Society. Subscriptions for the Journal are also accepted. The Society welcomes, from members and non-members, manuscripts of research and review articles in all branches of science, art, literature and philosophy for publication in the Journal and Proceedings.

Editorial

Sometimes an Editor gets lucky. This issue of the Society's Journal is one such time. I had no need to search for a topic to pen this Editorial on, as one just presented itself as the Journal came together over the past few months – the importance of *analysis* when studying a problem and seeking better understanding about its nature. Analysis is, of course, fundamental, to the scientific process, and at the heart of any interpretation of data, whatever field it arises from. But analysis can be a two-edged sword. Used well it informs, and provides depth to interpretations. Used inappropriately it can do the opposite, leading to mis-understanding, and yielding conclusions that are wrong, possibly with unfortunate consequences for decisions taken as a result. Proficiency in the many methods of analysis, and an appreciation of what information might sensibly be extracted from a data set, as well as what is inappropriate, or simply not warranted, is a necessary and indispensable element in gaining knowledge and understanding from it. On the other hand, making decisions based upon a belief or a gut feeling, without seeking to undertake just a little analysis on the issue at hand, may serve to perpetuate a misunderstanding, and lead to inappropriate actions.

The need for *just a little analysis* is the subject of David Wilson's – the winner of the Society's 2013 Edgeworth David Medal – opening discourse to this issue of the Journal, in this case focussed on applications for improving public health. Analysis can, of course, be complex. Sometimes it may

be presented as unnecessarily so, and the mathematical techniques applied then serve to obfuscate the issue. However complexity may lie at a problem's heart, and inappropriate simplification to make it apparently tractable might not be the way to inform understanding. Bruce Henry, Head of the School of Mathematics at UNSW, gives us an applied mathematicians response to the matter of analysis and its application.

Two other articles in this Journal also contain analysis at their heart. John Page tells us about the development of engineering simulations, and how they may be used to provide insight into the behaviour of some complex systems, in particular for the development of virtual reality systems. Brett Gooden, in a completely different application, examines how an organism from the early days of evolution on our planet, the Ediacaran *Dickinsonia*, might have been able to breath – through developing a simplified physical model for the process that is then amenable to a quantitative analysis regarding the rapidity of oxygen diffusion.

The two other articles to this issue are firstly from the Society's James Cook Medallist, Brien Holden and colleagues, on the important public health issue of correcting refraction error in vision, and secondly from John Nichols who applies an analysis to data on the performance of bond wrenches.

Michael Burton
Hon. Secretary (Editorial)
15 December, 2014



Just a little analysis...

David P. Wilson¹

2014 Edgeworth David Medal

¹Kirby Institute, University of New South Wales, Sydney, Australia

Abstract

In this invited discourse it is argued that simple analyses of the most important components of a complex situation, providing logic and rationality, when communicated clearly and in a timely manner can have the greatest impact in decision-making for society and industry. Drawing on experience in global and public health, I call on scientists who wish to directly influence decisions, to reduce complexity and remember the key principle behind Daniel Bernoulli's public health approach, namely, that decisions be based on 'all the knowledge which *a little analysis* can provide'.

Discussion

In a presentation to the French Academy of Sciences in Paris in 1760, Daniel Bernoulli stated that "*I simply wish that in a matter which so closely concerns the wellbeing of the human race, no decision shall be made without all the knowledge which a little analysis and calculation can provide*". At the time, smallpox was endemic throughout Europe and the cause of large-scale mortality [1]. Bernoulli implored the Academy to consider mass vaccination against smallpox as a public health strategy. This was possibly the first time that a public health approach was considered rather than individual-level interventions purely for personal benefit. With simple calculations using life tables, and assumed probabilities for the risk of catching smallpox and its case fatality, he concluded that "*by adopting universal inoculation against smallpox, France would gain 25 000 additional useful 'Civil Lives' which would benefit the state and society*". This analysis was published in 1766 [2]; a recent commentary on Bernoulli's paper was published in 2004 [3].

In today's technological world of iPhones, computerized motor vehicles, and generation of 'big data' from Omics fields in biology, scientists usually employ complex

scientific and analytical methods. This is necessary when designing the next iPhone or algorithm for a medical robot but it is not necessary for issues related to policy decisions. In my approach to public health research, I am inspired to not lose sight of the key principle behind Bernoulli's public health approach, namely, that decisions be based on 'all the knowledge which *a little analysis* can provide'.

It is important to acknowledge the actual manner in which policy and public programming decisions are made; quite simple, there is no systematic method. Ideally, governments aspire to make decisions that achieve the best overall outcomes, but there are numerous conflicting exogenous, ideological, and institutional influences in their decision-making and the process involves multiple stakeholders exerting varying degrees of influence [4]. Political factors, as well as historical precedent, are probably the primary drivers of many decisions rather than scientific-based evidence. Bernoulli besought that within this mix rational simple analytical arguments can provide insights to inform decisions and that there may be the potential for profound outcomes. Similarly, I exhort scientists who

wish to directly influence decisions, made by governments or industry leaders, to keep this principle at the fore in the conduct and communication of scientific investigation.

I was honoured to be presented with the Edgeworth David Medal by the Royal Society of NSW at a ceremony in May 2014 for my scientific contributions of applied mathematics in the area of infectious disease global health. It provided me with an opportunity to reflect on what I considered to be valuable in my contributions, what facilitated their translation to be influential, and my future research approach. I concluded that at least in my area of application, all it takes is just a little analysis, through conduct of good yet simple science on the most important broad questions being asked in the field, communicated in a straightforward manner, to lead to widespread change in policy and/or practice.

The allure of applied quantitative analysis for young scientists is often to the idea that intellectually stimulating mathematics can be useful for industry or society. Although there tends to be the promise of informing decisions, the field of applied mathematics in academic settings tends not to be about applying mathematics directly but often about exploring ‘mathematically interesting’ phenomena of complex systems of equations which may somewhat describe the dynamics or processes of a real-world system. The mathematical exploration does not advance, or provide insight into, the application and nor does it advance fundamental mathematical theory. Communication of findings may involve some esoteric and obscure mathematical description, alienating the discipline of application even further. In contrast, pure mathematicians often portray no deception

about the uselessness of their complex theorems and mathematical research. In my opinion there are two fundamental shifts that are needed among quantitative scientists, which may also be relevant to other scientific disciplines, if they wish to be truly applied: (1) realize that simple approaches that directly address topics of relevance, and focus on the key factors of importance, are more useful than complex analyses that are difficult to investigate and understand; (2) realize that clear communication of the main messages and the essential components that explain these results are just as, or even more, important than the science itself. In my experience in the area of policy decisions, even if the analyses are only around 70% complete or precise but are communicated clearly and through appropriate channels then they are likely to inform the decision-making process. However, an analysis which is not able to meet the usually short timeframes in which decisions are made or not communicated well to compete with other advocacy arenas, even if conducted much more rigorously, will ultimately remain a purely academic exercise without influence.

Scientific analyses have been greatly influential in many spheres of industry and society. The purest of scientific methods, mathematics, can be powerful when applied well. However, due to the nature of the fundamental tool, mathematics, it is inclined to be largely theoretical and miss out on its great potential. It is important to remember that the emphasis in the term ‘applied mathematics’ is not in the word ‘mathematics’ but in that it is ‘applied’. To realize aspirations of using science to change decisions, particularly mathematics to inform public health decisions, the process should involve collating available evidence, investigating the crux of the

decision area at hand and addressing it with just... a little analysis.

References

1. Creighton C. A History of Epidemics in Britain, 2nd edn. Cambridge University Press: London, 1894.
2. Bernoulli D. Essai d'une nouvelle analyse de la mortalite causee par la petite verole. Mem Math Phy Acad Roy Sci Paris 1766. (English translation entitled 'An attempt at a new analysis of the mortality caused by smallpox and of the advantages of inoculation to prevent it'. In Smallpox

Inoculation: An Eighteenth Century Mathematical Controversy, Bradley L. Adult Education Department: Nottingham, 1971, 21).

3. Blower S, Bernoulli D (2004) An attempt at a new analysis of the mortality caused by smallpox and of the advantages of inoculation to prevent it. 1766. Rev Med Virol 14: 275-288.
4. Jan S, Dommers E, Mooney G (2003) A politico-economic analysis of decision making in funding health service organisations. Soc Sci Med 57: 427-435.

Associate Professor David Wilson completed his PhD on infectious disease modelling in 2003, studying at Oxford University, ETH Switzerland and Queensland University of Technology. He then did a postdoctoral fellowship at UCLA on HIV epidemic modelling and optimal allocation of HIV antiretroviral drugs. From 2005, A/Prof Wilson has been based at UNSW where he coordinates Australia's national HIV surveillance and reporting. Winner of a Eureka Prize and the Royal Society of NSW's Edgeworth David Medal in 2013, he is also the leader of the UNSW and World Bank Optima team which conducts modelling, health economic and resource allocation studies for national governments around the world, as well as regional and global bodies and large international donors.

Received: 27 June 2014

Accepted: 29 July 2014



An Applied Mathematician's Apology

Bruce Henry¹

¹School of Mathematics and Statistics, UNSW, Sydney, Australia

E-mail: b.henry@unsw.edu.au

Abstract

In this article I provide a personal perspective on what Applied Mathematics is and why it is important. The academic discipline of Applied Mathematics sits somewhere between, and across, the academic discipline of Pure Mathematics and the pragmatism of applications. Much of the domain of Applied Mathematics is abstract and may not appear to be useful for real world applications. However it is through such abstractions that new mathematics is created and the rich mapping between the physical universe and mathematics, which is necessary for applications, is advanced.

Introduction

Let me begin by conveying my sincere congratulations to Professor David Wilson for his very nice work in applying mathematics, which has been recognized by the Royal Society of New South Wales with the Edgeworth David Medal for 2013.

In his invited discourse in this issue David provides a short critique of the academic discipline of Applied Mathematics. In his view this discipline has diverged from the pursuit of applying mathematics to real world systems; becoming instead an activity of mathematical exploration that “does not advance, or provide insight into, the application and nor does it advance fundamental mathematical theory.” David goes further by contrasting this with the academic discipline of Pure Mathematics. Here he says, there is “no deception about the uselessness of their complex theorems and mathematical research.” David urges mathematical scientists, with interests in applications of mathematics, to reduce complexity in their analysis and to concentrate on providing clear and timely advice. In illustration of his message he draws attention to Daniel Bernoulli's seminal paper on mathematical

epidemiology, a translation of which can be found in Blower (2004).

I welcome the opportunity to provide a defence of the academic discipline of Applied Mathematics.

An Apology¹

I do not fully agree with David's description of the academic discipline of Applied Mathematics, but his observations are not entirely without justification. There is a vast literature of Applied Mathematics that may be considered permutations, involutions and explorations of complex model equations that are often far removed from any real world applications. There is also a significant literature that is more sharply focused on applications. It is my strong view that the academic pursuit of Applied Mathematics, including mathematical explorations, is vitally important. This academic pursuit enables the more practical pursuit of applying mathematics. One might intercede here and say that it is Pure

¹ The title is a variant of Godfrey Harold Hardy's 1940 essay “A Mathematician's Apology”. Readers of Hardy's essay will observe that while he strongly defended Pure Mathematics he made rather disparaging remarks about Applied Mathematics.

Mathematics that enables the practical pursuit of applying mathematics. There is truth in this too; the kingdom needs a King and a Queen.

In order to present a defence of the academic discipline of Applied Mathematics it is useful to attempt to define what it is that Applied Mathematicians do². There is no absolute definition that I am aware of, and in some ways a definition might be regarded as a philosophical position. As context, for my definition, I consider an expanding universe of mathematics, created purely from imagination³, that exists in parallel with the physical universe that we inhabit and create. Pure Mathematicians explore and extend the universe of mathematics, developing and imagining new vistas. Applied Mathematicians build on and further develop the universe of mathematics to enable mathematics to be used to provide understanding, prediction and improvements, including technological developments, in the physical universe. Pure Mathematicians and Applied Mathematicians are of course both mathematicians and it is not possible to define an absolute boundary between them. Mathematical scientists who are applying mathematics to inform policy makers are dependent on structures created by both Pure Mathematicians and Applied Mathematicians. The number of mathematical scientists has grown enormously over the past two centuries

extending through the quantitative disciplines of economics, computer science, engineering, actuarial science, bioinformatics etc. The number of Applied Mathematicians and Pure Mathematicians is small compared with the cohort of mathematical scientists applying mathematics.

As an academic Applied Mathematician, I have never used my knowledge of mathematics to attempt to influence decision-making and hence my comments on this will be based on logic rather than experience. It certainly makes sense to explain things simply, with simple analysis, if you are attempting to inform policy makers who are not very mathematically literate. However this does not mean that the analysis itself should be simple. With time constraints it makes sense to reduce explorations but it is also makes sense to be mindful of the well known aphorism, often attributed to Albert Einstein, “Everything should be made as simple as possible, but not simpler”⁴. There can be more than one model, and one set of analysis; one, which is a simplification to communicate the essence to policy makers, and another, which has sufficient mathematical complexity to convince mathematical scientists of its validity. The schematic figure eight flight trajectories for the Apollo moon missions come to mind in this context, contrasted with the complicated mathematical calculation of the actual Earth-Moon-Earth trajectory of the spacecraft. The figure eight

² Hardy posed the question “How do pure and applied mathematicians differ from one another?” and he immediately followed this with “This is a question which can be answered definitely and about which there is general agreement among mathematicians.” However he didn’t provide a direct answer to the question.

³ There is no consensus on whether mathematics are created or discovered. I have adopted a non-Platonist philosophical position on this.

⁴ When Einstein developed a mathematical model for general relativity he found it necessary to go beyond the mathematics of vector analysis and Euclidean geometry, and to use the mathematics of tensor analysis. Tensor analysis was the mathematics that was needed to be able to describe the geometry of a four-dimensional space-time. Tensor analysis would never have been an option without the mathematical explorations that developed it.

trajectory is a cartoon. The moon is in motion relative to the position of the Earth and it is travelling about five times faster than the spacecraft when the spacecraft gets near the moon (Crenshaw, 2010).

It is not difficult to find examples where simple analysis fails. If you plot Olympic Gold Medal winning and Olympic Silver Medal winning 100-metre sprint times as a function of year, since 1896 you will find an approximate linear fit between Gold Medal winning times and the year, and a different linear fit between Silver Medal winning times and the year. In each case the medal winning times decrease approximately linearly as a function of time, with the slope of the best fit for Silver Medal times being greater than the slope of the best fit for Gold Medal times. Having different slopes means that the lines must cross over at some future point in time. Naïve advice based on this simple analysis would then suggest that at some point in the future, Silver Medal athletes would be running faster than Gold Medal athletes in this event. This conclusion is of course fanciful nonsense but it is not entirely a straw man argument. A similar simple analysis, published in *Nature* (Tatem et al, 2004), led to the conclusion that women would have faster sprint times than men in the 100-metres event in the 2156 Olympics.

Those mathematical scientists involved in applying mathematics to advise policy makers should be prepared to embrace the most relevant mathematics in their modelling. They should be prepared to engage in cutting edge mathematics, if needed, and they should be prepared to have dialogues with Applied Mathematicians and Pure Mathematicians. Daniel Bernoulli’s work on epidemiology followed this paradigm. The aim of

Bernoulli’s epidemiology paper (Blower, 2004), published in 1766, was to find the increase in life expectancy of a newborn, if there was inoculation against smallpox. His analysis might be considered simple for some practicing mathematicians today, but it was not simple at the time. It was disputed by a contemporary of Bernoulli, the Applied Mathematician, D’Alembert (Dietz and Heesterbeek, 2002). Daniel Bernoulli was by no means an ordinary mathematician. He also had access to state of the art mathematical methods through contact with his uncle Jakob, and earlier, with his father Johann. Daniel Bernoulli’s paper contained the first formulation of a mathematical model for the spread of an epidemic in terms of ordinary differential equations. After some elegant analysis, Bernoulli reduced the mathematical model to a special type of differential equation that he could then solve using a method devised by his uncle, Jakob Bernoulli. This special type of differential equation belongs to a class of differential equations now known as Bernoulli equations. The development of methods of solution for that class of differential equations is a classic example of exploration in Applied Mathematics.

The techniques for simple mathematical analysis do not spontaneously come into existence. They follow earlier mathematical explorations. Sometime ago I used simple analysis to calculate the possibility of executing a fundamental surfing manoeuvre; dropping down the face of a wave, doing a bottom turn, and returning to the top of the wave before it breaks (Henry and Watt, 1998). A slightly simpler problem of this type (the *Brachistochrone Problem*) was originally set as a challenge “to the most clever mathematicians in the world” by Johann Bernoulli in 1696. Solutions were obtained by the giants in mathematics; Isaac

Newton, Gottfried Leibniz, Guillaume de L’Hopital, Jacob Bernoulli and Johann Bernoulli. At the time their solutions might have appeared as complex explorations far removed from any significant real physical system – the shortest time path for a point like object to slide from rest without friction under the action of a constant force. However their Applied Mathematics explorations led to the formulation of the calculus of variations, and this is now a mainstay of all optimization problems where the object is to find a function that maximizes or minimizes some specified constraints.

As a general principle it makes sense to reduce the complexity of the analysis if possible, especially if timely advice is important. But it is also important to provide accurate advice, or at least to provide advice on the level of accuracy. David alludes to this but does not give it prominence; “even if the analyses are only around 70% complete or precise but are communicated clearly and through appropriate channels then they are likely to inform the decision-making”. This 70% idea is like the Pareto 80/20 principle for time management, which roughly states that for many situations 80% of the complete or precise result may be obtained from 20% of the effort needed to get the complete or precise result. This can guide time allocation but in providing advice the accuracy of the advice should play a prominent role. The advice should contain reliability estimates. This may necessitate going beyond simple analysis.

The Global Financial Crisis of 2007, 2008, brought the importance of accurate advice into sharp focus. It is generally accepted that a major contributor to this crisis was inaccurate advice from financial advisors

who did not properly understand risk (Taleb & Martin, 2012). Some of this inaccurate advice was based on a formula that was derived from the simplifying assumption that the price of Credit Default Swaps was correlated with the price of mortgage-backed securities (Salmon, 2009). The formula was popular because it could deliver quick and decisive advice but the simplifying assumption was flawed.

It may be possible to go beyond simple analysis and still provide clear and timely advice that is far more reliable than simple analysis could provide. This is the case in modern weather forecasting. An example of simple analysis in this context is the persistence model for weather forecasting. This model predicts that tomorrow’s weather will be the same as today’s weather. Modern weather forecasting is not simple analysis, but it can be done in a timely fashion to provide clear and accurate advice. It evolved to this level of sophistication after two hundred years of Applied Mathematics explorations in partial differential equations, nonlinear dynamics and computational mathematics.

Applied Mathematics is the mapping, and further development, connecting and extending mathematics with the physical universe, including the creation of new technologies. This definition connects a little with Galileo’s view that the universe is like a grand book, written in the language of mathematics. Galileo remarks that “it is humanely impossible to comprehend a single word” “until we have learnt the language and become familiar with the characters in which it is written”. In this context, Pure Mathematics could be construed as the language of the universe with Applied Mathematics playing the role of an interpreter and an author, enabling the

physical universe to be understood and extended through new technologies. As an example, the discovery or invention of natural numbers could be considered as Pure Mathematics. The discovery and development of natural numbers for the purpose of counting and ordering could be considered as Applied Mathematics. Using natural numbers for counting and ordering could be considered as applying mathematics. I am not suggesting that this is historically how things evolved in this example. It is almost certainly true that counting preceded the creation, or was the creation of natural numbers. The marks on the Ishango bone⁵, believed to be 20,000 years old, may be one of the earliest examples of a counting system. Prime numbers, the fundamental theorem of arithmetic, and the prime number theorem are in the domain of Pure Mathematics, but the creation of public key encryption methods based on prime numbers is Applied Mathematics. Applying mathematics to the security of Internet financial transactions is dependent on such methods.

In general, discoveries or inventions in Pure Mathematics lead to discoveries and inventions in Applied Mathematics and vice versa. The fundamental elements of calculus, derivatives and integrals, may be considered as the domain of Pure Mathematics but the discovery and development of calculus to describe rates of change in real world phenomena is Applied Mathematics. Again there is no definitive boundary but this can be used as a guide. In this case we might consider Leibniz’s calculus as Pure Mathematics and Newton’s calculus as Applied Mathematics. Some historians have argued that much of what we would regard as Pure Mathematics

evolved out of Applied Mathematics through the 19th and 20th centuries (Maddy, 2008).

As a further example, the Navier-Stokes partial differential equations, which were developed by Claude-Louis Navier in 1822 and George Gabriel Stokes in 1854 are fundamental to all modern weather forecasting models. Their study, development, and implementation in this context is Applied Mathematics. However the determination of whether or not smooth solutions always exist for these equations in three-dimensions is currently an open problem in Pure Mathematics⁶. Weather forecasts by any of the myriad providers are examples of applying mathematics.

As a final example, let me discuss an area of current interest in Applied Mathematics that I am somewhat familiar with. This is the area of fractional calculus. The history of fractional calculus in Pure Mathematics goes back to the foundations of calculus more than three hundred years ago. One of the founders of Calculus, Gottfried Leibniz, in a letter to Guillaume de L’Hôpital in 1695 posed the question (Miller and Ross, 1993): *“Can the meaning of derivatives with integer order be generalized to derivatives with non-integer orders?”* At the time, L’Hôpital was writing the first textbook on calculus⁷. Many Pure Mathematicians became interested in this problem and developed expressions for fractional derivatives and fractional integrals. The fractional calculus first appeared in Applied Mathematics when

⁶ This is one of the seven Millennium Prize Problems established by the Clay Mathematics Institute in 2000 as an important classic question whose solution deserves a million dollar prize.

⁷ *Analyse des Infiniment Petits pour l’Intelligence des Lignes Courbes (Analysis of the infinitely small to understand curves)* (1696).

⁵ http://en.wikipedia.org/wiki/Ishango_bone

Niels Abel made mention of it in his 1823 paper on the *Tautochrone Problem*. This problem was to find the curve for which the time taken for a point like object to slide from rest, under the influence of gravity, and without friction, to reach the lowest point is independent of the starting point. The optimal curve is a cycloid, which is also the solution to the *Brachistochrone Problem*.

It is only in recent decades that fractional calculus has started to have a significant impact in Applied Mathematics. The motivation for this interest has its origins in many physical and biological experiments that reported diffusion of particles some orders of magnitude slower than that anticipated by Albert Einstein’s *Theory of Brownian Motion*. A reconsideration of diffusion, derived from the mathematics of continuous time random walks, and taking into account the effects of particle trapping and obstacles, has led to the creation of new mathematical models of diffusion, including new diffusion equations with fractional order temporal derivatives. The new models, which can provide a better fit to data, have stimulated a lot of explorations in Applied Mathematics. These explorations are now starting to flow back to Pure Mathematics.

Most mathematical biologists seeking to apply mathematics to problems of diffusion are not yet equipped to venture far beyond Einstein’s model of Brownian motion. It may be sometime yet before the fractional calculus enters the domain of what any applied practitioner might regard as simple analysis. However, without the pursuits of Pure Mathematics and Applied Mathematics it never could. There is currently a lot of exploration in Applied Mathematics developing fractional calculus models with only tenuous links back to any

real world system. Some of this, on its own, indeed most of it, may well turn out to be useless. But it is this overall level of activity that produces a breeding ground that is necessary for creating new, and potentially useful, results. This activity also provides a platform to train the next generation of scientists who will be able to incorporate newly created methods into possible simple analysis in a multidisciplinary setting.

Related to the example above, I would like to mention in passing that it is generally the case among tertiary education providers around the world to provide less mathematics training for students in the biological sciences than those in the physical sciences and engineering. This should not be the case. We should not limit those applying mathematics in the biological sciences to a handful of tools enabling simple analysis.

We live in challenging times. The human population of more than seven billion is altering its global environment and climate; the well-being of our economic and financial systems is largely predicated on future growth that is unsustainable; our global connectedness through airline networks, and internet networks, make us vulnerable to global shocks; the demands on our medical systems and transport systems is exceeding capacity; the emergence of terrorism on a global scale poses enormous threats to security. Meeting these challenges will require intellectual advances from science, medicine, engineering, finance and business.

One of the global tasks of mathematicians is to extend the universe of mathematics and to provide the mathematical training that will help to underpin and enable these challenges to be met. Mathematics is not

static. It is not something that we have and know in its entirety. It is something that is evolving. It is created by Pure Mathematicians and by Applied Mathematicians through explorations. The activities in our world are increasingly being underpinned by mathematics, and decision makers are increasingly reliant on advice that is underpinned by mathematics. There is no doubt that clear and timely advice, based on accurate and uncomplicated mathematical analysis, will be valuable and sought after. But so will the fruits of mathematical explorations, offering methods of analysis and prediction not yet imagined.

Acknowledgements

I very much benefitted from discussions with Dr Bernard Kachoyan, Dr Chris Angstmann and Isaac Donnelly for their thoughts on this. Their views do not necessarily align entirely with mine and any errors in the paper are of course entirely my own.

References

Blower, S. (2004) An attempt at a new analysis of the mortality caused by smallpox and of the advantages on inoculation to prevent it, *Reviews in Medical Virology*, 14, 275-288.

Bruce Henry is Head of the School of Mathematics and Statistics at the University of New South Wales. He is an Applied Mathematician with more than seventy international journal publications across many different discipline areas, including: applied mathematics, biology, condensed matter physics, geology, materials science, mathematical physics, plasma physics, stochastic process, neuroscience and vision science. For the past fifteen years most of his research has been focussed on developing and combining continuous time random walks, fractional calculus and stochastic analysis, to provide model equations for the motions of particles that react and diffuse in environments with traps, obstacles and external forces.

Received: 5, November 2014

Accepted: 6, November 2014



- Crenshaw, J. (2010) Fly me to the moon;
Embedded,
<http://www.embedded.com/electronics-blogs/programmer-s-toolbox/4211093/Fly-me-to-the-Moon>
- Dietz, K. and Heesterbeek, J. A. P. (2002) Daniel Bernoulli’s epidemiological model revisited,
Mathematical Biosciences, 180, 1-21.
- Hardy, G. H. (1940) A mathematician’s apology;
<http://www.math.ualberta.ca/mss/>
- Henry, B. I. and Watt, S. D. (1998) Surfing Brachistochrones; *Parabola*, 34, Issue 3.
- Maddy, P. (2008) How applied mathematician’s became pure, *The Review of Symbolic Logic*, 1, 16-41.
- Miller, K. S. and Ross, B. (1993) *An Introduction to the Fractional Calculus and Fractional Differential Equations*, John Wiley and Sons. Inc., New York.
- Salmon, F. (2009) Recipe for Disaster: The Formula That Killed Wall Street; *Wired Magazine*, Issue 17-03, 2009.
- Taleb, N. and Martin, G. (2012) How to Prevent Other Financial Crises; *SAIS Review*, XXXII, No 1.
- Tatem A. J., Guerra C. A., Atkinson P. M. and Hay S. I. (2004) Athletics: Momentous sprint at the 2156 Olympics? *Nature*, 431. 525.

The Evolution of Uncorrected Refractive Error as a Major Public Health Issue

This paper is an expanded version of the address given at the award of the 2013 James Cook Medal for Science and Humanity by the Royal Society of New South Wales.

Brien Holden^{1,2,3*}, Stephen Davis^{1,3}, Monica Jong¹, Serge Resnikoff^{1,2}

¹Brien Holden Vision Institute, Sydney, Australia

²University of New South Wales, Sydney, Australia

³Vision Cooperative Research Centre, Sydney, Australia

* Corresponding author

E-mail: b.holden@brienholdenvision.org

Abstract

Uncorrected refractive error has only recently (2006) been formally recognised as a significant cause of blindness and the major cause of impaired vision in the world. It is now known that over 625 million people have uncorrected refractive error (for distance and near vision), simply because of a lack of an eye examination and appropriate spectacles.

Accumulating evidence indicates that myopic macular degeneration (MMD) is a major cause of vision impairment and blindness – but this contribution of MMD to blindness prevalence is yet to be recognised by the World Health Organization (WHO) and national research bodies such as the US National Eye Institute (NEI). In 2010, there were an estimated 1.7 billion myopes worldwide – predicted to increase to around 2.2 billion by 2020 – with a small but significant percentage of those affected likely to progress to high myopia. High myopia significantly increases the risk of blinding conditions such as MMD, glaucoma and cataract.

This article details the crucial epidemiological work and advocacy efforts that have positioned uncorrected refractive error on the global health agenda and charts the evolution of myopia as a major public health issue which still requires a supreme coordinated effort to combat this encroaching ‘epidemic’.

Keywords: uncorrected refractive error; myopia; presbyopia; blindness; myopic macular degeneration; vision impairment

Uncorrected refractive error – the major cause and most easily treated form of vision loss

More than half of the world population experiences clinically significant refractive errors for distance or near vision. In the United States (2004), for example, 55% of the

US population 40 years and older had clinically significant distance refractive errors such as myopia, hyperopia and astigmatism (Vitale et al., 2008) and over 100 million people (32% of the population) were presbyopic in 2005 (Holden et al., 2008).

On World Sight Day 2006, the WHO released its 2004 findings that 153 million people were either blind or visually impaired due to uncorrected distance refractive error (World Health Organization, 2006).

The WHO Assistant Director General, Dr Catherine Le Gales-Camus, said in the associated press release: “These results reveal the enormity of the problem. This common form of visual impairment can no longer be ignored as a target for urgent action.”

Even today the lack of available spectacle correction around the world is a major issue. In 2005, over one billion people (15% of the world population) had near refractive error (presbyopia) and more than half (517 million) were uncorrected (Holden et al., 2008).

In 2014, 108 million had uncorrected distance refractive error (Bourne et al., 2013). Altogether, 625 million people (9% of the world population) were still blind or vision impaired due to uncorrected distance and near refractive error. Despite WHO declaring uncorrected refractive error a global priority, agencies and civil society, with one or two exceptions, have been slow to respond.

Recognition of uncorrected refractive error

The impact of uncorrected vision impairment, whether distance or near, includes increasing social isolation, reduced employment and educational opportunities, increased morbidity and poverty (World Health Organization, 2006, Khanna et al., 2007, Naidoo, 2007, Taylor et al., 2006, Holden, 2007).

Key events that helped bring the issue of uncorrected refractive error to the forefront included the formation of the Refractive

Error Working Group of the International Agency for the Prevention of Blindness (IAPB), the inaugural World Congress on Refractive Error and Service Development in Durban, South Africa (2007) and a key paper published in the Bulletin of the World Health Organization by Resnikoff et al. (2008).

The recognition of uncorrected refractive error required a change in the definition of vision impairment and blindness used by the International Statistical Classification of Diseases and Related Health Problems (ICD-10) from “best corrected distance visual acuity (vision with correction)” to “presenting distance visual acuity”.

The limitation of the current ICD-10 classification is that it still excludes hundreds of millions of people (the majority living in developing communities) with near vision impairment.

In 1999, the IAPB and WHO jointly launched the Vision 2020: The Right to Sight initiative, which set the ambitious goal of eliminating avoidable blindness by the year 2020.

Cost of eliminating the burden of uncorrected refractive error

Studies have shown that the global cost of uncorrected refractive error due to lost productivity was US\$202 billion each year (Smith et al., 2009, Fricke et al., 2012).

Part of the issue is the lack of availability of eye care personnel and to address this, a complex program of optometry school development, human resource development, infrastructure, affordable equipment and spectacles is required.

Addressing both distance and near uncorrected refractive error globally would require an investment of US\$28 billion over 5 years (Fricke et al., 2012).

The US\$28 billion would cover:

- 47,000 functional clinical eye care providers – to assess vision and eye health and prescribe corrective lenses needed to restore good vision;
- 18,000 optical dispensers – to provide appropriate glasses;
- Establish the service delivery facilities needed;
- Operating costs for facilities for 5 years, after which it is assumed that revenue generated by the service would cover costs.

The next phase would be to secure the continual support and funding to build the human resources and sustainable eye care systems required.

Despite uncorrected refractive error now being firmly on the blindness prevention agenda, it has yet to become a primary activity of the vast majority of non-governmental organisations (NGOs) and there is a general lack of awareness at the health ministry level.

Uncorrected presbyopia

As mentioned earlier, the ICD-10 definition of vision impairment and blindness is based on “distance visual acuity” only, resulting in 517 million people with uncorrected presbyopia (near vision impairment) unrecognised, despite uncorrected presbyopia being shown to have a similar quality of life impact as uncorrected distance vision impairment (Tahhan et al., 2013).

Uncorrected presbyopia is mentioned in the Resnikoff et al (2008) paper, where it is noted that “presbyopia is not included in this study given the present paucity of data, but it is recognized that uncorrected, it could lead to an impaired quality of life”, and further, in the paper’s conclusion, that presbyopia should be “...assessed and included in future estimates of visual impairment”.

The formal recognition of near visual impairment due to uncorrected presbyopia awaits the alteration of the definition of visual impairment from “distance visual impairment” to “distance and near visual impairment”.

The emerging threat of myopia

In addition to the burden of uncorrected refractive error, myopia and higher levels of myopia are a type of distance refractive error that is fast emerging as a major threat to vision throughout the world (Wong et al., 2014).

It is estimated that there were 1.7 billion myopes in 2010 and by 2020 there will be 2.2 billion (Holden et al., 2014). Despite a significant proportion of those having access to corrective lenses, the progressive nature of the condition means ongoing management is required. Although spectacle lenses provide an immediate solution to the poor distance vision resulting from myopia, they do not address the abnormal growth of the eyeball that occurs due to increasing levels of myopia which can lead to vision impairment and blindness later in life (Wong et al., 2014).

Higher levels of myopia, e.g. –6.00 dioptres or more (this level of myopia is often used as a ‘convenient’ arbitrary lower limit for ‘high myopia’, despite myopia being a continuum), lead to a significantly increased risk of sight-threatening conditions such as myopic macular degeneration (MMD) (Wong et al.,

2014), retinal detachment (The Eye Disease Case-Control Study Group, 1993), glaucoma (Qiu et al., 2013) and cataract (Younan et al., 2002).

Of growing concern is that a substantial number of those with moderate myopia will progress to high myopia and evidence is now mounting that MMD is a major cause of vision impairment and blindness (Iwase et al., 2006, Wu et al., 2011).

A recent study by Wu et al. (2011) found that MMD is now the leading cause of blindness in Jing-An District, Shanghai, China (26% of all new blindness cases reported in 2007-2009), with rates of blindness increasing from 113.7 per 100,000 in 2003 to 165.9 per 100,000 in 2009. Iwase et al. (2006) also found that MMD was a leading cause of blindness in Tajimi, Japan.

However, MMD is not yet recognised by the WHO as a significant cause of vision impairment or by national research bodies such as the US National Eye Institute (NEI) and other epidemiological surveys, due largely to the lack of a categorical definition for MMD.

The prevalence of myopia in East Asia is increasing at alarming rates. In Taiwan, the rate of myopia in 12 year-olds increased from 37% to 61% between 1983 and 2000 (Lin et al., 2004) and 96% of university freshmen (males and females) were myopic in 2005 (Wang et al., 2009). In South Korea, 97% of male army conscripts were found to be myopic (Jung et al., 2012), while in Singapore 65% of college graduates have been reported as having myopia (Au Eong et al., 1993). In China, a country of over 1.3 billion people, a 2003 study (He et al., 2004) revealed rates as high as 78% among 15 year-old children in urban areas.

Myopia is also impacting western nations. For example, in Australia, the prevalence of myopia in children whose parents both have myopia is 44% (Ip et al., 2007) and 31% of 17 year-olds were found to be myopic (French et al., 2013). In the United States, the prevalence has increased markedly in the last 30 years from 25% (1971-1972) amongst those aged 12 to 54 years to 42% (1999-2004) (Vitale et al., 2009). In 2010, it was estimated that there were 34 million myopes in the US and projected to increase to 44 million by 2050 (National Eye Institute, 2010).

Alongside the increase in the prevalence of myopia is also a growing prevalence in high myopia among younger age groups in some areas of Asia. For example, Lin et al. (1999) found that in Taiwan, 20% of 18-year-old girls had high myopia and a study in Singapore by Saw et al. (2005) found that 18% of 7-year-olds had high myopia.

This increase is not only evident in Asia. In the US, Vitale et al. (2009) reported an eight-fold increase in 'severe myopia' (defined as -7.9 diopters or above by the study authors) for the 18-54 years age group between 1971-1972 and 1999-2004.

Summary

The solution to uncorrected refractive error is simple but the logistics and planning complex. Sustainable solutions (not quick fixes) based on the development of human resources, infrastructure and affordable technology have proven to work best.

The elimination of this unnecessary burden on hundreds of millions of people needs to be achieved through scaled-up investment, and inclusive and intensified collaboration and community access through government,

civil society, educational systems and corporate collaborations and partnerships.

The threat of high myopia-induced blindness needs to be addressed by benchmarking, research and implementation of successful strategies for slowing the progress of myopia in children.

There is now an urgent need for epidemiological studies to determine the full extent of the threat posed by MMD, for advocacy efforts to generate greater awareness, for investment in the research and development of effective interventions, and for requisite action in the form of better provision of services and methods of prevention.

The simple issue of refractive error affects billions of people and its lack of correction and control have very far-reaching consequences on peoples' lives; science, technology, innovation and public and private health collaboration can make a huge difference to the outcome.

References

- Au Eong, K. G., Tay, T. H. & Lim, M. K. 1993. Education and myopia in 110,236 young Singaporean males. *Singapore Medical Journal*, 34, 489-92.
- Bourne, R. R., Stevens, G. A., White, R. A., Smith, J. L., Flaxman, S. R., Price, H., Jonas, J. B., Keeffe, J., Leasher, J., Naidoo, K., Pesudovs, K., Resnikoff, S., Taylor, H. R. & Vision Loss Expert, G. 2013. Causes of vision loss worldwide, 1990-2010: a systematic analysis. *Lancet Glob Health*, 1, e339-49.
- French, A. N., Morgan, I. G., Mitchell, P. & Rose, K. A. 2013. Risk factors for incident myopia in Australian schoolchildren: the Sydney adolescent vascular and eye study. *Ophthalmology*, 120, 2100-8.
- Fricke, T. R., Holden, B. A., Wilson, D. A., Schlenther, G., Naidoo, K. S., Resnikoff, S. & Frick, K. D. 2012. Global cost of correcting vision impairment from uncorrected refractive error. *Bulletin of the World Health Organization*, October.
- He, M., Huan, W., Zheng, Y., Huang, L. & Ellwein, L. B. 2004. Refractive error and visual impairment in urban children in southern China. *Investigative Ophthalmology and Vision Science*, 45, 793-799.
- Holden, B. A. 2007. Blindness and poverty: a tragic combination. *Clin Exp Optom*, 90, 401-3.
- Holden, B. A., Fricke, T. R., Wilson, D. A., Jong, M., Naidoo, K. S., Sankaridurg, P., Frick, K. D. & Resnikoff, S. 2014. Prevalence of myopia and high myopia now, in 2030 and 2050 (in preparation).
- Ip, J. M., Huynh, S. C., Robaei, D., Rose, K. A., Morgan, I. G., Smith, W., Kifley, A. & Mitchell, P. 2007. Ethnic Differences in the Impact of Parental Myopia: Findings from a Population-Based Study of 12-Year-Old Australian Children. *Investigative Ophthalmology & Visual Science*, 48, 2520-8.
- Iwase, A., Araie, M., Tomidokoro, A., Yamamoto, T., Shimizu, H., Kitazawa, Y. & Tajimi Study, G. 2006. Prevalence and causes of low vision and blindness in a Japanese adult population: the Tajimi Study. *Ophthalmology*, 113, 1354-62.
- Jung, S.-K., Lee, J. H., Kakizaki, H. & Jee, D. 2012. Prevalence of Myopia and its Association with Body Stature and Educational Level in 19-Year-Old Male Conscripts in Seoul, South Korea. *Investigative Ophthalmology & Visual Science*, 53, 5579-5583.
- Khanna, R., Raman, U. & Rao, G. N. 2007. Blindness and poverty in India: the way forward. *Clin Exp Optom*, 90, 406-14.
- Lin, L. L., Shih, Y. F., Hsiao, C. K. & Chen, C. J. 2004. Prevalence of myopia in Taiwanese

- schoolchildren: 1983 to 2000. *Annals of the Academy Of Medicine, Singapore*, 33, 27-33.
- Lin, L. L., Shih, Y. F., Tsai, C. B., Chen, C. J., Lee, L. A., Hung, P. T. & Hou, P. K. 1999. Epidemiologic study of ocular refraction among schoolchildren in Taiwan in 1995. *Optometry & Vision Science*, 76, 275-81.
- Naidoo, K. 2007. Poverty and blindness in Africa. *Clin Exp Optom*, 90, 415-21.
- National Eye Institute. 2010. Myopia [Online]. Available: <http://www.nei.nih.gov/eyedata/myopia.asp#4> [Accessed 3 October 2014].
- Resnikoff, S., Pascolini, D., Mariotti, S. & Pokharel, G. P. 2008. Global magnitude of visual impairment caused by uncorrected refractive errors in 2004. *Bull World Health Organ*, 86, 63-70.
- Saw, S. M., Tong, L., Chua, W. H., Chia, K. S., Koh, D., Tan, D. T. H. & Katz, J. 2005. Incidence and Progression of Myopia in Singaporean School Children. *Investigative Ophthalmology & Visual Science*, 46, 51-57.
- Smith, T. S. T., Frick, K. D., Holden, B. A., Fricke, T. R. & Naidoo, K. S. 2009. Potential lost productivity resulting from the global burden of uncorrected refractive error. *Bulletin of the World Health Organization*, 87.
- Tahhan, N., Papas, E., Fricke, T. R., Frick, K. D. & Holden, B. A. 2013. Utility and uncorrected refractive error. *Ophthalmology*, 120, 1736-44.
- Taylor, H. R., Pezzullo, M. L. & Keeffe, J. E. 2006. The economic impact and cost of visual impairment in Australia. *Br J Ophthalmol*, 90, 272-5.
- The Eye Disease Case-Control Study Group. 1993. Risk factors for idiopathic rhegmatogenous retinal detachment. The Eye Disease Case-Control Study Group. *Am J Epidemiol*, 137, 749-57.
- Vitale, S., Ellwein, L., Cotch, M., Ferris, F. L., Iii & Sperduto, R. 2008. Prevalence of refractive error in the United States, 1999-2004. *Archives of Ophthalmology*, 126, 1111-1119.
- Vitale, S., Sperduto, R. D. & Ferris, F. L. 2009. Increased prevalence of myopia in the United States between 1971-1972 and 1999-2004. *Archives of Ophthalmology*, 127, 1632-9.
- Wang, T.-J., Chiang, T.-H., Wang, T.-H., Lin, L. L.-K. & Shih, Y.-F. 2009. Changes of the ocular refraction among freshmen in National Taiwan University between 1988 and 2005. *Eye*, 23, 1168-1169.
- Wong, T. Y., Ferreira, A., Hughes, R., Carter, G. & Mitchell, P. 2014. Epidemiology and disease burden of pathologic myopia and myopic choroidal neovascularization: an evidence-based systematic review. *Am J Ophthalmol*, 157, 9-25 e12.
- World Health Organization. 2006. Sight test and glasses could dramatically improve the lives of 150 million people with poor vision [Online]. World Health Organization website. Available: <http://www.who.int/mediacentre/news/release/s/2006/pr55/en/> [Accessed 7 October 2014].
- Wu, L., Sun, X., Zhou, X. & Weng, C. 2011. Causes and 3-year-incidence of blindness in Jing-An District, Shanghai, China 2001-2009. *BMC Ophthalmol*, 11, 10.



Segmentation and Oxygen Diffusion in the Ediacaran *Dickinsonia*: an Applied Analysis

Brett Gooden¹

¹Wellington Caves Fossil Studies Centre,
89 Caves Road, Wellington, NSW 2820, Australia

E-mail: bagooden@bigpond.net.au

Abstract

Many Ediacarans are constructed of multiple parallel segments. Two forms of segment were analysed in the present study, a cylindrical and cuboidal form. The theoretical surface area to volume (A/V) ratio of a structure composed of cylindrical segments is twice that of one composed of cuboidal segments of the same thickness. In this analysis the Ediacaran *Dickinsonia* was assumed to be a bottom-dwelling marine animal. Individual A/V ratios were calculated for 60 fossil specimens of *Dickinsonia* of known thickness and diameter assuming either a structure composed of tapering cylinders (conical frusta) or tapering cuboids (square frusta). With increasing body diameter a lower limit of the A/V ratio was approached in both structural forms at a body diameter of approximately 50 millimetres. The segments were assumed to contain solid connective tissue. The theoretical oxygen concentration gradient due to simple diffusion into both forms was calculated and the effect of a collagenous segmental wall on these gradients was determined. The cylindrical form with a collagenous wall was found to be viable within the constraints of this analysis but not the cuboidal form. The findings support the hypothesis that *Dickinsonia* could have obtained adequate oxygenation by simple diffusion with cylindrical but not cuboidal segments.

Keywords *Dickinsonia*, Ediacarans, segmentation, oxygen diffusion.

Introduction

In 1964 Berkner and Marshall hypothesised that the trigger for the emergence of metazoans was the appearance of oxygen in the atmosphere. Since then the estimated oxygen content of the Precambrian atmosphere has progressively increased (Butterfield, 2009; Canfield, 2007; Shields-Zhou, 2011), which raises once more the vexed question of the relationship between the structure and the mode of oxygen delivery in the Ediacaran biota (Raff, 1970; Runnegar, 1982).

The characteristic surface feature of many species of Ediacaran is a repeated parallel segmentation. In 1989 Seilacher suggested that a wide range of Ediacarans including *Pteridinium* and *Dickinsonia* had a common structural form composed of parallel chambers underlying the defining surface segmentation (Figs. 1, 2 and 3). He represented these chambers as essentially cuboidal in shape. Grazhdankin (2002) drew these chambers as purely box-like or cuboidal in form with square cross section.

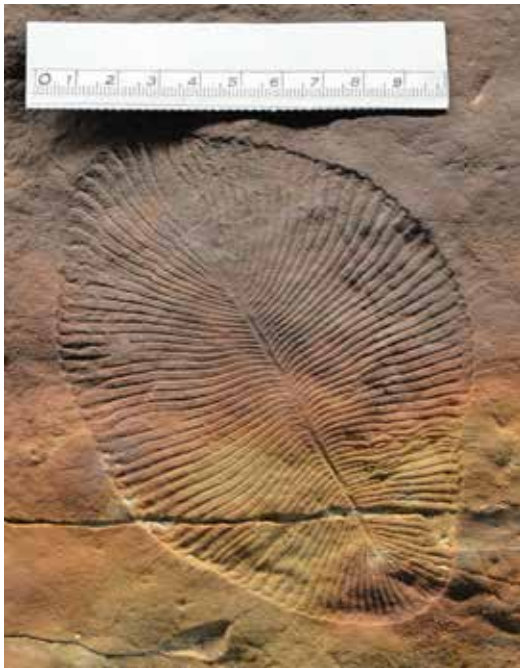

Figure 1: Fossil of *Dickinsonia*. Scale in centimetres (South Australian Museum, specimen No. P49355).



Figure 2: Fossil of *Pteridinium*. Scale in centimetres (specimen by courtesy of Dr Jim Gehling, South Australian Museum).

The surface area to volume (A/V) ratio is critical for the survival of marine organisms that are dependent solely on the diffusion of oxygen from a watery environment through their surface and into their living tissue (Krogh, 1941; Alexander, 1971). Laflamme

(2009) modelled *Pteridinium* on the basis of a cuboidal structure in order to analyse the A/V ratio. However illustrative material presented by Jenkins (1992) raised the possibility that the segments in *Pteridinium* may have been more cylindrical than cuboidal in shape and recent photographic evidence lends further support to this concept (Elliott, 2011).

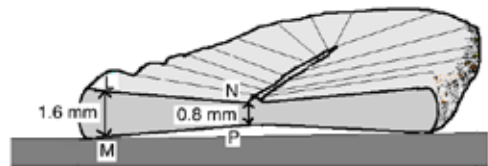

Figure 3: Schematic diagram of *Dickinsonia* lying on the biomat covering the ocean floor (dark grey shaded area) showing a section through a tapering cylindrical segment and diffusion paths LM of thickness 1.6 mm adjacent to the periphery and NP of thickness 0.8 mm adjacent to the midline.

Recently Retallack (2012) has suggested that some Ediacarans including *Pteridinium* and *Dickinsonia* were terrestrial organisms similar to lichens. Though the matter is clearly contentious, it would appear that the generally held view at the present time is that the Ediacarans were marine organisms (Switek, 2012) and for the purposes of the present palaeo-physiological analysis the author has assumed that to be the case.

The first objective of the present study was to analyse theoretically the A/V ratio of two hypothetical structural forms, one composed of purely cylindrical segments and the other of purely cuboidal segments. These ratios were then applied to data from actual fossil specimens of *Dickinsonia* in which the profile thickness and diameter were known. In this way the A/V ratio of each specimen could be calculated for either a purely cylindrical or cuboidal form of segmentation and compared. Finally, the

theoretical oxygen concentration gradient in cylindrical and cuboidal segments was calculated and considered in relation to the possible viability of each structural form.

Methods

Factors affecting the A/V ratio

Ratio of diametrical length to arc length

Consider a section composed of n semicircular arcs, then

$$l_a/l_d = n \cdot \pi \cdot r / n \cdot 2r \quad (1)$$

where l_a is the total arc length of the section, l_d is the total diametrical length of the section and r is the radius of an arc (Fig. 4). Rearranging Eq. 1 $l_a = l_d \cdot \pi/2$.

Therefore rolling a section of n arcs flat increases its diametrical length by a factor of 1.57 times (see Fig. 8B).



Figure 4: Portion of a section of n semicircular arcs of radius r . The arc length is π/r and the diametrical length is $2r$, hence the ratio of the arc length to the diametrical length is $\pi/2$.

A/V ratio of a cuboidal segment

Consider a hypothetical cuboidal segment with square cross section and length L .

$$A_{cub}/V_{cub} = 4 \times L/4 \times L^2 = 1/x \quad (2)$$

where A_{cub} is the surface area (upper plus lower surfaces only) of the cuboidal

segment exposed to the external environment, V_{cub} is the volume of the segment and x is half the length of a side of the square cross section (Fig. 5).

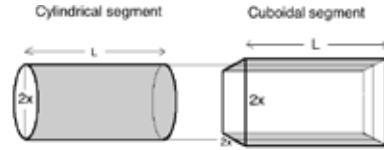

Figure 5: Cylindrical and cuboidal segments. Lateral view. Shaded area indicates surface in contact with external watery environment.

A/V ratio of a cylindrical segment

Consider a hypothetical cylindrical segment of the length L .

$$A_{cyl}/V_{cyl} = \pi \cdot 2x \cdot L / \pi \cdot x^2 \cdot L = 2/x \quad (3)$$

where A_{cyl} is the surface area of the cylindrical segment exposed to the external environment, V_{cyl} is the volume of the cylindrical segment and x is the radius of the cylinder (Fig. 5).

A/V ratio of a hypothetical Dickinsonia constructed of tapering cuboidal segments

Tapering cylindrical segment Tapering cuboidal segment

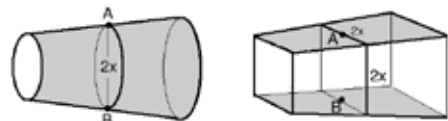

Figure 6A: Tapering cylindrical (conical frustum) and tapering cuboidal (square frustum) segments. With reference to points A and B, see Fig. 11 and 12.

$$A_{Dtub}/V_{Dtub} = 2 \pi R^2 / \pi R^2 \cdot 2x = 1/x \quad (4)$$

where A_{Dtub} is the surface area of a tapering cuboidal segment (square frustum), (upper plus lower surfaces only) exposed to water,

V_{Dicub} is the volume of the segment, R = half the mean overall diameter of the *Dickinsonia* and x = half the mean thickness of the *Dickinsonia* (Fig. 6A and B).

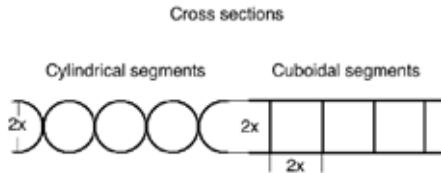

Figure 6B: Portion of the cross section of a hypothetical *Dickinsonia* constructed of either cylindrical or cuboidal segments.

A/V ratio of a hypothetical Dickinsonia constructed of tapering cylindrical segments

$$A_{D_{cyl}}/V_{D_{cyl}} = (\pi R)^2/(\pi R)^2 \times 2 = 2/x \quad (5)$$

where $A_{D_{cyl}}$ is the surface area of tapering cylindrical segment (conical frustum) exposed to water and $V_{D_{cyl}}$ is the volume of the segment. R and x as in (4) (Fig. 6A and B).

Note: This hypothetical calculation assumes that there is no loss in surface area of a cylindrical segment at the junctions between segments (see Discussion).

Factors affecting the rate of diffusion of oxygen

Fick's first law

$$\partial v/\partial t = A \cdot D \cdot \partial c/\partial x \quad (\text{Prosser, 1961}) \quad (6)$$

where $\partial v/\partial t$ = volume of oxygen ∂v that diffuses in time ∂t , A = the area of the surface across which the oxygen diffuses into the tissue, D = the diffusion coefficient of oxygen in the tissue, ∂x = the distance the oxygen diffuses into the tissue and ∂c = the concentration gradient of oxygen in the tissue, that is, the difference in the oxygen concentration from the

beginning to the end of the diffusion distance ∂x .

The maximum diffusion distance for oxygen in a cuboidal segment of connective tissue

$$s = \sqrt{C_0 2D_{CT} / M_{CT}} \quad (7)$$

(Warburg, 1923; Alexander, 1971)

where s = half the thickness in millimetres (mm) of a viable cuboidal segment of connective tissue in which oxygen diffuses from both upper and lower surfaces, C_0 = the difference in oxygen concentration, expressed as a fraction of one atmosphere, from either surface of the segment to half its thickness where the oxygen concentration falls to zero, D_{CT} = the diffusion coefficient of oxygen in connective tissue in millilitres (ml) of oxygen diffusing per cubic centimetre of surface area per minute at a pressure gradient of one atmosphere per centimetre of tissue thickness (= 0.11×10^{-4}), M_{CT} = the rate of oxygen consumption of connective tissue in ml of oxygen per gram of tissue per minute (=1/600).

The maximum diffusion distance for oxygen in a cylindrical segment of connective tissue

$$r = \sqrt{C_0 4D_{CT} / M_{CT}} \quad (8)$$

(Fenn, 1927; Alexander, 1971)

where r = maximum radius of a viable cylinder of connective tissue in mm, C_0 = the difference in the oxygen concentration, expressed as a fraction of one atmosphere, from the surface of the cylindrical segment to its central axis where the oxygen concentration falls to zero. D_{CT} and M_{CT} as in (7).

Source of data for the analysis of profile thickness to diameter in Dickinsonia

Retallack (2007) measured the width, length and profile depth of 94 specimens of *Dickinsonia* from the Flinders Ranges. Data from 60 of these specimens, where Retallack gave complete measurements for the specimens, have been analysed. In order to measure the profile depth or thickness of each fossil, Retallack (2007) used a device called a depth gauge with which he measured the “general levels rather than details of the ribbing”. In order to take into account the inevitable variability of such measurements, Retallack's profile thickness measurement is assumed to be the average profile thickness of a specimen. The diameter was calculated for each specimen by averaging its length and width values.

Estimation of atmospheric oxygen during the Ediacaran Period

The present partial pressure of oxygen in the atmosphere at sea level, ignoring water vapour pressure, is 21.3 kilopascals (kPa). Canfield (2005) estimated the levels of atmospheric oxygen over the last billion years. Using this graphical information as the basis for calculations in the present paper, the atmospheric partial pressure of oxygen during the Ediacaran period was estimated to be 4, 8 and 12 kPa at the beginning, middle and end of the Ediacaran period respectively.

Oxygen consumption of Ediacaran connective tissue

The specific nature of the tissue components of Ediacaran organisms is unknown. However one histological component that would *a priori* be expected to compose a portion of the organism is

connective tissue. Connective tissue consists largely of fibroblasts and a non-cellular component called extracellular matrix (ECM), which is secreted by the fibroblasts. ECM forms the framework of metazoan organisms and binds their cells together. Collagen is the major component of ECM (Cell Biology @ Yale, 2014). Genetic studies indicate that collagen has remained remarkably constant throughout the evolution of animals (Garrone, 1999). It therefore seems likely that fibroblastic cells, not unlike those of today, produced collagenous ECM in the Ediacarans. Furthermore it would be most unlikely that Ediacaran connective tissue would have a rate of oxygen consumption greater than it is today; if anything it would be expected to be less (Mills, 2014). Therefore the conservative assumption will be made here that the rate of oxygen consumption in connective tissue during the latter part of the Ediacaran period was the same as it is today.

Graphical representation of the oxygen concentration gradient

The theoretical concentration gradient of oxygen from ocean water into the tissue of segmental Ediacarans under consideration can be represented graphically (Fig. 7) (Alexander, 1971; Math Bench, 2014). The concentration of oxygen in well-mixed ocean water is assumed to be directly proportional to the partial pressure of oxygen in the atmosphere in contact with the water (Henry's law), consequently the Ediacaran tissue oxygen concentration gradient can also be represented as a gradient of oxygen partial pressure (Krogh, 1941). The precise three dimensional pattern of oxygen diffusion through living tissue is highly complex, never-the-less this representation of the oxygen concentration gradient provides a workable basis for the

purpose of a comparison of cylindrical and cuboidal forms in the present study.

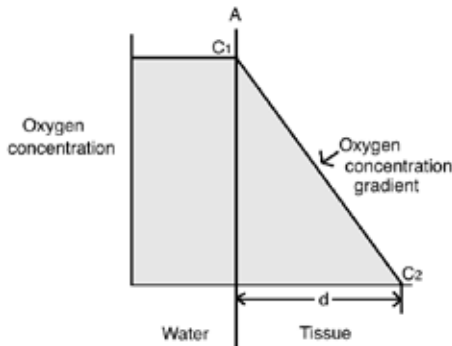

Figure 7: Graphical representation of the oxygen concentration in the water of the external environment and in the tissue of the internal environment of an organism. The two environments come into contact at A. Oxygen concentration is shown on the vertical axis and distance on the horizontal axis. C_1 is the concentration of oxygen in the water bathing the organism. d is the maximum distance that oxygen diffuses in time t at which point the oxygen concentration has decreased to C_2 . The straight line joining C_1 and C_2 represents the theoretical oxygen concentration gradient.

Results and Discussion

Segmental structures in *Pteridinium* and *Dickinsonia*

The fossils of many species of Ediacaran appear to be sheet- or sail-like, that is they are relatively thin in cross section compared with their overall size. An example of this form of Ediacaran is *Pteridinium* (Fig. 2) that appears to have consisted of three elongated leaf-like structures called vanes (Richter, 1955; Seilacher, 1989). The surfaces of these vanes are divided transversely into multiple parallel segments (Narbonne, 1997). Underlying this surface segmentation, Seilacher (1989) envisaged compartments which he called the “quilted pneu structure”. He believed that this

structure could be applied to a range of Ediacarans, including *Pteridinium* and *Dickinsonia* (Fig. 1). Grazhdankin (2002) suggested these box-like chambers ended blindly at both ends, were supported hydrostatically by enclosed sediment and could be represented schematically as cuboids of square cross section.

Jenkins’ (1992) drawing of the cross section of a *Pteridinium* vane from a fossil specimen was suggestive that at least some chambers of the vane were actually more circular than square in cross section and approximately 1.6 mm in diameter. Recent photographic evidence (Elliott, 2011) further supports the concept that a *Pteridinium* vane may have been composed of a single row of tubules of approximately 1.6 mm diameter. Grazhdankin (2002) suggested that a segment could collapse with partial to complete flattening. Such flattening would be expected to result in an increase in the width of the surface segmentation with a proportionate decrease in the segment depth. For example complete collapse of a cylindrical segment with an initial circular diameter of 1.6 mm would theoretically result in a flattened segment width of 2.5 mm, that is, similar to widths of segments measured by Richter (1955) in the first detailed study of *Pteridinium*.

In general the segments in *Pteridinium* do not taper greatly from one end to the other. In the oval shaped *Dickinsonia* on the other hand, the segments fan out from a mid-line ridge and their width generally increases from the midline to the periphery (Fig. 1 and 3). The larger the *Dickinsonia* the greater the number of segments and the profile of the corrugations becomes flatter (Sprigg, 1949; Seilacher, 1989). Consequently the mean width of a *Dickinsonia* segment tends to remain

remarkably constant regardless of the overall size of different specimens.

Effect of corrugations on surface area

The surface segmentation is corrugated to a varying extent in the fossils of both *Pteridinium* and *Dickinsonia*. An important question is “What was the shape of the cross section in the living segments?” since the cross sectional shape of the segment influences the surface area for oxygen diffusion (Eq. 6). One could consider a range of possibilities by progressively morphing the segment from a purely cuboidal to a purely cylindrical form.

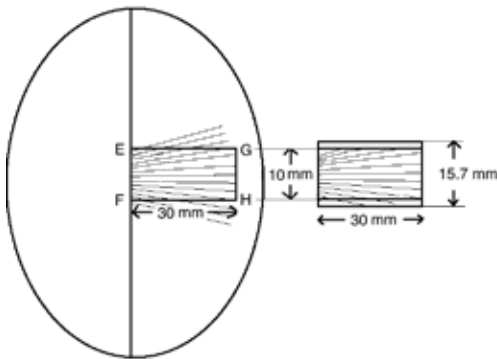

Figure 8A: Effect of segmentation on the theoretical surface area in *Dickinsonia* (Fig. 1 shows the original specimen). Consider a rectangular area EFGH on the fossil's surface of width 10 mm and radial length 30 mm from the midline. This 10 mm width is found to enclose 12 segments adjacent to the midline, section EF, and half this number at the radial distance of 30 mm from the midline, section GH. Assuming that the cross section of each segment is a perfect semicircle, then if this rectangular corrugated area is rolled flat, the resulting flat area would be increased by $\pi/2$ or 1.57 times (Eq. 1) (Note: diagram is not strictly to scale).

In a surface composed of segments of perfectly semicircular cross section, the surface area is increased by a factor of $\pi/2$,

that is 1.57 times, compared with a surface made up of perfectly flat surfaced segments (Eq. (1); Fig. 4). Thus within any rectangular area of the surface of any given width and radial length, the increase in the surface area due to the contained corrugations is independent of the number of segments. A larger number of segments of smaller radius has the same rolled flat length as a smaller number of segments of larger radius (Fig. 8A and 8B).

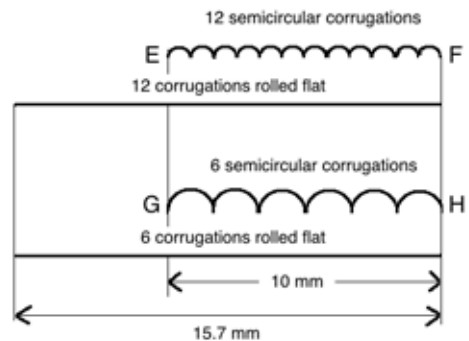

Figure 8B: If the semicircular segments in sections EF and GH, as shown in Fig. 8A, are rolled flat, they will both measure the same length despite the fact that EF contains 12 semicircular segments and GH six segments.

Thickness versus diameter in *Dickinsonia*

The majority of the 60 fossils specimens had a profile thickness of less than 2.5 mm and the mean thickness was 1.42 ± 0.96 mm (\pm standard deviation) (Fig. 9). The mean value of all of the diameters of these specimens was 52.7 ± 41.0 mm. The greatest diameter of an individual fossil was 259 mm. Clearly *Dickinsonia* is generally very thin in relation to its diameter.

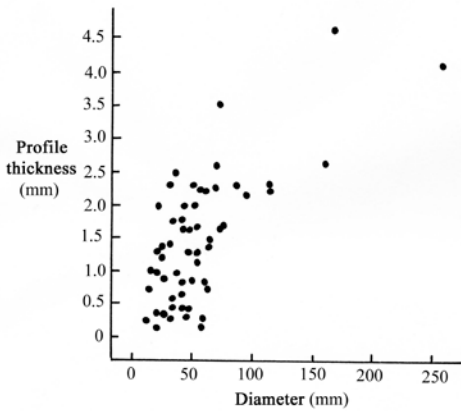

Figure 9: Profile thickness (mm) versus diameter (mm) in *Dickinsonia* fossils ($n=60$; based on raw data from Retallack, 2007).

Argument for a three dimensional tapering structure of *Dickinsonia* segments

As already discussed the surface appearance of the segmental corrugations of *Dickinsonia* clearly shows that the segments taper from periphery to midline. Seilacher (1989) showed that segmentation exists on both the upper and lower surfaces of *Dickinsonia*. The following analysis is based on the hypothesis that *Dickinsonia* consisted of a single layer of segments and that these structures tapered from the periphery to the midline. Each segment will be considered as either a tapering cuboid (square frustum) or tapering cylinder (conical frustum) (Fig. 6A).

A/V ratio in *Dickinsonia* composed of tapering cuboidal or tapering cylindrical segments

The A/V ratio of 60 fossil specimens of *Dickinsonia* was calculated on the theoretical basis that the structure consisted of either tapering cylindrical or tapering cuboidal segments (Eq. (4) and (5)). *Dickinsonia* with the smallest overall fossil diameters had the highest A/V ratios. The graph of the

individual data points indicates that at an average diameter of approximately 50 mm the steep decline in the A/V ratio approaches a lower limit and does not decrease significantly below this ratio despite a considerable increase in the diameter of the organism (Figs. 10A and 10B).

In the case of a hypothetical *Dickinsonia* composed of tapering cylindrical segments this lower limit of the A/V ratio is approximately two and in the case of a *Dickinsonia* based on tapering cuboidal segments it is approximately unity (Fig. 10A and B).

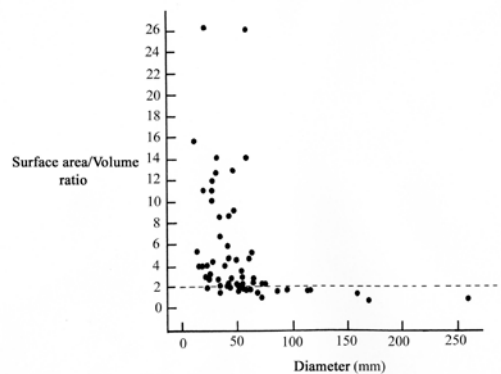

Figure 10A: Surface area to volume (A/V) ratio versus diameter (mm) in *Dickinsonia* fossils of known profile thickness and diameter but assuming that they are composed of tapering cylindrical segments ($n=60$; based on raw data from Retallack, 2007). Dotted line indicates an A/V ratio of 2.0.

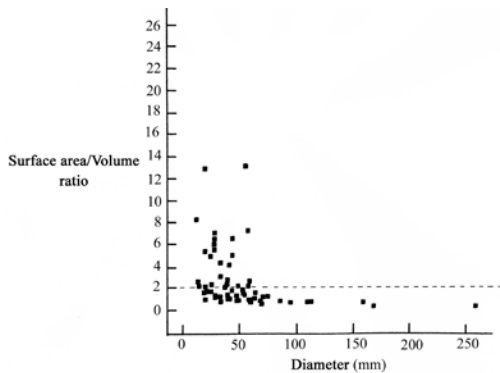

Figure 10B: Surface area to volume (A/V) ratio versus diameter (mm) in the same *Dickinsonia* fossils as shown in Fig. 9A but assuming that they are composed of tapering cuboidal segments. Dotted line indicates an A/V ratio of 2.0.

In the analysis of the hypothetical structure of *Dickinsonia* based on tapering cylindrical segments, there is theoretically no loss in surface area at the point of contact between adjacent cylinders. On the other hand in the case of the tapering cuboids, half the surface area is lost as a result of the contact between adjacent segments. The theoretical A/V ratio in the cylindrical segment was $2/x$ and in the cuboidal segment $1/x$ (Eq. (2) and (3)). Since x , half the mean thickness of a segment, is the same in both cases, it is clear that the A/V ratio of the cylindrical structure is twice that of the cuboidal structure. It is also clear that progressively morphing from a purely cylindrical form to a purely cuboidal form will progressively reduce the difference in A/V ratio from two to one as the area of contact between adjacent segments increases. The actual structural form of the segments in Ediacarans like *Pteridinium* and *Dickinsonia* would be expected to be the result of competitive evolutionary pressure which on one hand would tend to maximise the A/V ratio and on the other maximise the structural strength of the connection between adjacent segments.

Oxygen concentration gradient in a cuboidal segment and a cylindrical segment

At the time of the first non-mobile forms of Ediacarans, approximately 580 million years ago, the partial pressure of the oxygen in the atmosphere is estimated to have been 9.3 kPa and at the time of the first mobile Ediacarans 555 MYA 12 kPa (Fike, 2006). *Pteridinium* and *Dickinsonia* are believed to have co-existed during the latter part of the Ediacaran period. Therefore the estimate of 12 kPa will be used in the present analysis. The segments are assumed to be biological structures filled with living connective tissue (see Methods).

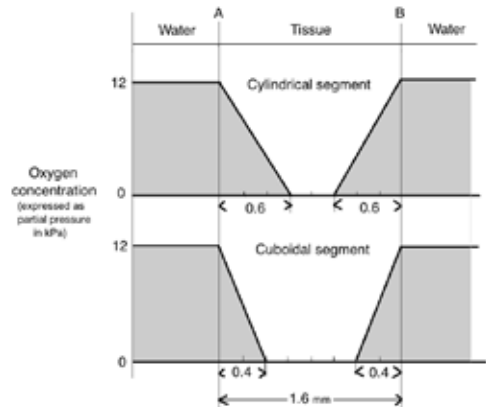

Figure 11: Theoretical oxygen concentration gradient from ocean water into a cylindrical and cuboidal segment with ultra-thin segmental walls at A and B that have no effect on oxygen diffusion. With reference to points A and B see Fig. 6A.

In the initial analysis the wall separating the seawater from the living tissue of the segment is assumed to be a thin membrane with no significant effect on oxygen diffusion (Fig. 11). The oxygen concentration profile along a straight line between points A and B is examined (see also Fig. 6A). The distance between these

points, that is the thickness of the segment, is taken to be 1.6 mm (see earlier).

In the case of a cuboidal segment, the maximum oxygen diffusion distance was 0.4 mm (Eq. (7)). Thus oxygen diffusing from points A and B would fail to reach the centre of the cuboidal segment leaving an anoxic gap of 0.8 mm in the central region of the segment. On this basis the cuboidal segment would not have been viable.

In the case of the cylindrical segment, the maximum diffusion distance is 0.6 mm (Eq. (8)). In this case however the anoxic gap is halved to 0.4 mm, but the cylindrical segment would still not be viable.

Effect of a segmental wall on the oxygen concentration gradient

Dzik (1999) suggested that the apparently flexible walls of the segments of Ediacarans were probably composed of “collagenous fabric”. He argued that these collagenous sheaths were more resistant to post-mortem decay than the presumed cellular contents of the segments and therefore more likely to be fossilised. He proposed that the segmental walls were relatively thick. Recent three-dimensional microCT findings of Meyer (2014) indicate that the walls of *Pteridium* were flexible and therefore consistent with a composition of connective tissue. They also reported that their findings support the “traditional interpretation” of a semi-benthic or epibenthic lifestyle.

The diffusion coefficient of oxygen in acellular collagenous gel is approximately 2.5 times greater than that in connective tissue (Krogh, 1919). It is generally held that the former material, as in mesogloea, is “metabolically inert”, that is it consumes virtually no oxygen (Chapman, 1953; Bouillon, 1968; Raff, 1970). The combined

effect of these two factors, a greater oxygen diffusion coefficient and a negligible oxygen consumption, would be expected to result in a considerable increase in the rate of diffusion of oxygen through a collagenous wall compared with the same thickness of living connective tissue (Eq. (7) and (8)). A comparative study by Schick (1979) on sea anemones supports this basic concept.

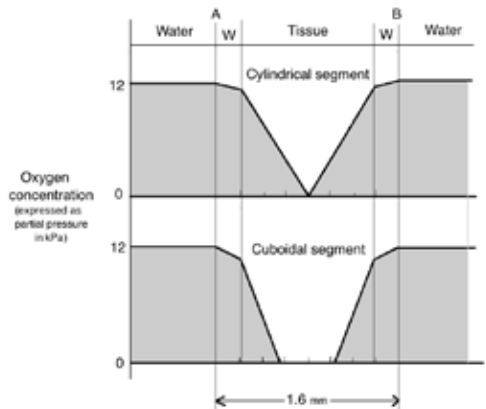

Figure 12: Theoretical oxygen concentration gradient from ocean water into a cylindrical segment and cuboidal segment with 0.2 mm thick collagenous segmental walls, W, at A and B. With reference to points A and B see Fig. 6A.

If it is assumed conservatively that the metabolic rate of an acellular collagenous wall is $1/10^{\text{th}}$ that of living connective tissue and its oxygen diffusion coefficient is 2.5 times greater than connective tissue (see earlier), then the maximum diffusion distance for oxygen in a cylinder of collagenous gel would be 3.0 mm (substitution in Eq. (8)), which is a five fold increase in the maximum diffusion distance compared with that in living connective tissue. Thus a collagenous segmental wall would be expected to significantly increase the maximum depth of oxygen diffusion into the segment (Fig. 12). Assuming a wall substance with such characteristics, it is found that in order for oxygen to reach the

centre of a 1.6 mm thick cylindrical segment containing living connective tissue, the wall thickness of the segment would need to be approximately 0.2 mm. On the other hand, if a cuboidal segment of connective tissue had the same wall thickness, there would remain a central anoxic gap of 0.5 mm and this structure would still be not be viable (Fig. 12).

Recently Laflamme (2009) modelled *Pteridinium* on the basis of a cuboidal structure and analysed the A/V ratios for a range of sizes. These workers assumed that their cuboidal structure was hollow and examined wall thicknesses from 1.6 mm to 0.01 mm. They found that such structures with a A/V ratio of around one had a wall thickness of 1.6 – 0.5 mm. Similarly the present study determined that a *Pteridinium* vane constructed of cuboidal segments made of solid tissue 1.6 mm thick, an A/V ratio of 1.25 (substituting in Eq. (2), $1/0.8$) would be inadequate to supply oxygen the 0.8 mm distance to the centre of the structure (see Fig. 11 and 12). They came to the conclusion that for their hollow cuboidal structure to be viable it would require oxygen diffusion from both the inner and outer surfaces with a thin component of living tissue of less than 0.5 mm thickness and with the segments open at one end to allow the entry of ocean water. However with only a single opening, stagnation of water with hypoxia would be expected in such a chamber with little improvement in oxygen supply. Also segmental openings along the free edges of the vanes in *Pteridinium* fossils have not been observed to date.

Laflamme (2009) did not examine a cylindrical form of segmentation nor did they specifically analyse their cuboidal structure in relation to oxygen diffusion.

Interestingly, however, they determined that megabacteria which rely upon diffusion for their oxygen supply generally have A/V ratios of approximately two or greater. The present study of *Dickinsonia* found that the majority of specimens analysed also had an A/V ratio of two or greater when this ratio was calculated on the basis of a cylindrically segmented structure.

Habitus and the oxygen concentration gradient in *Dickinsonia*

It has been suggested that *Dickinsonia* was a mobile Ediacaran and able to seek out its food supply (Seilacher, 1989; Gehling, 2005). If it is assumed that *Dickinsonia* was constructed of tapering cylindrical segments of maximum thickness of approximately 1.6 mm, this study has shown that such a segmented structure could have provided adequate oxygenation provided that oxygen was free to diffuse into the tissue from both sides of the segment. However at times *Dickinsonia* may have remained stationary in order to digest the underlying biomat (Fig. 3).

Under these conditions the ocean water trapped beneath the organism could have become increasingly stagnant and hypoxic. A significant reduction in oxygen partial pressure would have been unlikely in the segmental tissue near the periphery of the organism since the surface corrugations would have facilitated access to fresh ocean water (Fig. 3, diffusion path LM). More at risk might have been the segmental tissue closer to the midline of the organism (Fig. 3, diffusion path NP). However if the segments tapered in thickness towards the midline, as suggested in this study, then the tissue diffusion distance would be progressively reduced towards the centre of the *Dickinsonia* thereby facilitating an

adequate oxygen supply from the upper surface alone if necessary.

Acknowledgements

The author wishes to acknowledge the valuable critique by Dr Jim Gehling of the author's presentations to the Friends of the South Australian Museum held in the Royal Society of South Australia Rooms, Adelaide on 12 February and 12 March 2014 entitled "Shaping the Ediacarans" which provided the bases for this paper. In addition Dr Gehling kindly provided the author access to *Pteridinium* fossil specimens. He also wishes to thank Dr Robert Palmer for his valuable comments regarding the mathematical analysis and Dr Michael Augee for his general comments on the manuscript.

References

- Alexander, R.M. (1971) *Size and Shape*, Edward Arnold, London, UK.
- Berkner, L.V. and Marshall, L.C. (1964) The history of oxygenic concentration in the earth's atmosphere; *Discussions of the Faraday Society*, **37**, 122-141.
- Bouillon, J. (1968) Introduction to Coelenterates in Florkin, M. & Scheer, B.I. (Eds.) *Chemical Zoology*, Academic Press, New York, U.S.A.
- Butterfield, N.J. (2009) Oxygen, animals and oceanic ventilation: an alternative view; *Geobiology*, **7**, 1, 1-7.
- Canfield, D.E. (2005) The early history of atmospheric oxygen: Homage to Robert M. Garrels; *Annual Review of Earth and Planetary Sciences*, **33**, 1-36.
- Canfield, D.E., Poulton, S.W., and Narbonne, G. (2007) Late-Neoproterozoic deep-ocean oxygenation and the rise of animal life; *Science*, **315**, 5808, 92-95.
- Chapman, G. (1953) Studies of the mesogloea of coelenterates; *Quarterly Journal of Microscopical Science*; **94**, 155-176.
- Cell Biology @ Yale (2014) Components of connective tissue, accessed 18 September 2014, <http://medcell.med.yale.edu/lectures/connective_tissue.php>
- Dzik, J. (1999) Organic membranous skeletons of Precambrian metazoans from Namibia; *Geology*, **27**, 6, 519-522.
- Elliott, D.A., Vickers-Rich, P., Trusler, P and Hall, M. (2011) New evidence on the taphonomic context of the Ediacaran *Pteridinium*; *Acta Palaeontologica Polonica*, **56**, 3, 641-650.
- Fenn, W.O. (1927) The oxygen consumption of frog nerve during stimulation; *Journal of General Physiology*, **10**, 767-779.
- Fike, D.A., Grotzinger, J.P., Pratt, L.M. and Summons, R.E. (2006) Oxidation of the Ediacaran ocean; *Nature*, **444**, 744-747.
- Garrone, R. (1999) Collagen, a common thread in extracellular matrix evolution; *Proceedings of the Indian Academy of Sciences (Chem. Sci.)* **111**, 1, 51-56.
- Gehling, J.G., Droser, J.G., Jensen, S.R. and Runnegar, B. N. (2005) Ediacaran organisms: relating form and function in D.E.G. Briggs (Ed.) *Evolving Form and Function: Fossils and Development*. Proceedings of the Symposium honoring Adolf Seilacher

for his contributions to palaeontology, in celebration of his 80th birthday. Peabody Museum of Natural History, Yale University, New Haven, pp. 43-67.

Grazhdankin, D. and Seilacher, A. (2002) Underground Vendobionta from Namibia; *Palaeontology*, **45**, 1, 57-78.

Jenkins, R.J.F (1992) Functional and early evolution of the Ediacaran assemblages in Lipps, J.H. & Signor, P.W. (Eds.) *Origin of Early Evolution of the Metazoa*; Plenum Press, New York, USA, pp. 131-176.

Krogh, A. (1919) The rate of diffusion of gases through animal tissues, with some remarks on the coefficient of invasion; *Journal of Physiology*, **52**, 391-408.

Krogh, A. (1941) *The Comparative Physiology of Respiratory Mechanisms*, University of Pennsylvania, Philadelphia, USA.

Laflamme, M., Xiao, S. and Kowalewski, M. (2009) Osmotrophy in modular Ediacaran organisms; *Proceedings of the National Academy of Sciences*, **106**, 34, 14438-14443.

Math Bench (2014) Cellular Processes. Diffusion: the gradient in Fick's first law, accessed 3 June 2014, <http://mathbench.umd.edu/modules/cell_processes_diffusion/page08.htm>

Mills, D.B., Ward, L.M., Jones, C., Sweeten, B., Forth, M., Treusch, A.H. and Canfield, D.E. (2014) Oxygen requirements of the earliest animals; *Proceedings of the National Academy of Sciences* **111**, 11, 4168-4172.

Meyer, M., Elliott, D., Wood, A.D., Polys, N.F., Colbert, M., Maisano, J.A., Vickers-Rich, P., Hall, M., Hoffman, K.H., Schneider, G. and Xiao, S. (2014) Three-

dimensional microCT analysis of the Ediacaran fossil *Pteridinium simplex* sheds new light on its ecology and phylogenetic affinity; *Precambrian Research* **249**, 79-87.

Narbonne, G.M., Saylor, B.Z. and Grotzinger, J.P. (1997) The youngest Ediacaran fossils from Southern Africa; *Journal of Palaeontology*, **71**, 6, 953-967.

Prosser, C.L. and Brown, F.A. (1961) *Comparative Animal Physiology*, W.B. Saunders Company, Philadelphia, USA, pp. 153-154.

Raff, R.A. and Raff, E.C. (1970) Respiratory mechanisms and the Metazoan fossil record; *Nature*, **228**, 1003-1005.

Retallack, G.J. (2007) Growth, decay and burial compaction of *Dickinsonia*, an iconic Ediacaran fossil; *Alcheringa*, **31**, 215-240.

Retallack, G.J. (2013) Ediacaran life on land; *Nature* **493**, 89-92.

Richter, R. (1955) Die ältesten Fossilien Süd-Afrikas; *Senckenbergiana Lethaea*, **36**, 3, 243-289.

Runnegar, B. (1982) Oxygen requirements, biology and phylogenetic significance of the late Precambrian worm *Dickinsonia*, and the evolution of the burrowing habit; *Alcheringa*, **6**, 223-239.

Schick, J.M., Brown, W.I., Dolliver, E.G. and Kayar, S.R. (1979) Oxygen uptake in sea anemones: effects of expansion, contraction, and exposure to air and the limitations of diffusion; *Physiological Zoology*, **52**, 50-62.

Seilacher, A. (1989) Vendozoa: organismic construction in the Proterozoic biosphere; *Lethaia*, **22**, 229-239.

Shields-Zhou, G. and Och, L. (2011) The case for a Neoproterozoic oxygenation event: geochemical evidence and biological consequences; *GSA Today*, **21**, 3, 4-11.

Sprigg, R.C. (1949) Early Cambrian “jellyfishes” of Ediacara, South Australia and Mount John, Kimberly District, Western Australia; *Transactions of the Royal Society of South Australia* **73**, 72-99.

Switek, B. (2012) Controversial claim puts life on land 65 million years early, accessed 18 September 2014, Nature [doi:10.1038/nature.2012.12017](https://doi.org/10.1038/nature.2012.12017)

Warburg, O. (1923) Versuch an überlebendem Carcinomgewebe (Methoden); *Biochemische Zeitschrift*, **142**, 317-333.

Brett A. Gooden obtained his M.B., B.S. and M.D. degrees from the University of Adelaide, where he undertook physiological research into breath-hold diving and aviation medicine. He continued his post-doctoral research on the comparative physiology of asphyxial defence as a Fulbright Scholar at the University of Texas Marine Biomedical Institute in Galveston. He was subsequently appointed a lecturer in physiology at the Queen’s Medical Centre Nottingham, in the UK, where he obtained a PhD for his work on the effects of hypoxia on the function of blood vessels from diving and terrestrial birds. He is currently an honorary research scientist at the Wellington Caves Fossil Studies Centre in New South Wales. His works include *Diving and Asphyxia* (1983, 2009; Cambridge University Press), *Echidna – extraordinary egg-laying mammal* (2006; CSIRO Publishing) and ‘The evolution of asphyxial defence’ (1993; in *Integrative Physiological and Behavioral Science*, 28, 4, 317-330).

Received: 7, September 2014

Accepted: 4, November 2014



Engineering Simulation – Frontier to a New Capability

John Page¹

¹Simulation and Virtual Engineering Laboratory
School of Mechanical and Manufacturing Engineering
University of New South Wales
Sydney NSW2052

* Corresponding author.
E-mail: j.page@unsw.edu.au

Abstract

The aim of this paper is to examine some of the issues relating to the fast developing technology of engineering simulation. While simulation has long played a part in human exploration of the physical and even philosophical ideas it is only with the relatively recent innovation of cheap computing power and software development that it has become a significant engineering tool. A brief introduction into the origin of physics based simulation is provided and then two specific areas of research are explored. The distinction between mathematical modelling and simulation is also addressed as both are often used inappropriately. The first specific area of research explored details of how deterministic chaos problems can be handled, particularly relating to harm minimisation in helicopter crashes, this shows how data with very little if any statistically based relationships can still provide useful design information. The second study relates to Self-Organised Swarms and how the individual agents can be modified to generate useful emergent behaviour. The modification is based on processes drawn from nature in particular evolution and learning from experience. The last part of the paper deals with philosophical issues which are becoming more challenging as the technology matures and Virtual Reality technology becomes widely available.

Introduction

The construction of imaginary worlds seems to have been a practice that dates back to pre-history. There have been three distinct uses in the broadest sense in which this human construct was deployed to further human evolution. These three have, however, always overlapped in a rather confusing manner. The first of these and the main subject of this paper was to use this imaginary or virtual world as a space to practice skills and tactics which could then be used in the real world. For this to succeed it is essential the generated world exhibits the same features and physics as the real world.

The difficulty in the early simulations, often war or hunting games for strategy development and training, as today, was to ensure that the participants took it seriously. This need and difficulty is demonstrated by the challenge set by Ho Lo to Sun Tzu, and related by him in *The Art of War* about 500 BCE, to train his concubines in military drill (Butler-Bowdon 2010). He made the King of Wu's favourite concubines company commanders, over the other women of the court, and when they failed to take their role in the enactment seriously he-headed them. This, we are told, led to the replacements taking their roles very seriously.

The second use of imaginary worlds in early history was in the form of games. Games have not only been used as a form of entertainment but also as generating a space where behavioural experiments can be carried out with limited risk. The board game Chaturranga which was a predecessor of Chess is not really an early simulation, despite some claims to the contrary, as it makes no attempt to mimic the real world. It may still, however, be seen as having value in developing strategic thinking. This trend continues into modern computer games where participants can have superhuman capabilities and many lives.

The third use of imaginary worlds that can be traced from pre-history until today is in a sense the hardest to categorise. This where the virtual world becomes a cultural construct in for example drama, dance, religions etc.

All three of these categories of activities require the participants, and often an audience, to suspend belief and enter a world they know to be not real. This is as true for the Captain of an Airbus 380 simulator as it is for the teenager playing shooter games in the bedroom or the actor playing Hamlet and his audience. In this sense the human behaviour is common but the intended outcomes are very different.

Engineering Simulation

It is quite difficult to define when simulation became a practical tool in the technologies. Many observers regard the Link Trainer as the first manifestation of a technical simulator.



Figure 1: The Link Trainer

The link trainer was a pilot trainer developed in the 1930s. It was credited with increasing the speed with which allied pilots could be trained in WW11 and certainly reduced the risks involved. While it is undoubtedly the precursor of modern flight simulators it was really more a procedural trainer than a true simulator. Training simulators, particularly flight simulators but also maintenance, and management simulators drove the technology up to a decade ago and still training in its many applications dominates the market.

Computer based simulation

The first computer based engineering simulators used analogue computers. The simple reason for this is that dynamic simulation involves the ability to integrate between acceleration and velocity and again between velocity and displacement. While analogue computers are well suited to integration digital computers are not and have to depend on numerical approximation. In order to provide sufficient accuracy a considerable amount of calculation is required, a limitation on computers of the day, and to provide a realistic flight experience this has to be accomplished in real time. Despite this disadvantage it was obvious that the development of analogue based flight simulators was restricted both by

their inherent unreliability and difficulty in programming.

The first reliable easily programmed digital flight simulators were ‘mimics’ (Page et al. 2006). The flight performance from a real flight case is recorded and then accessed as appropriate from look-up tables. This is a very efficient method for generating a flight simulator but does not involve any physics and is only applicable when operating within previously recorded events. This is still an approach that is often used particularly when a high fidelity is required that would involve a requirement for an unacceptably high computing capacity.

One common mistake in the application of these type simulators is to expect them to generate useful information in areas outside those built into the response. For example they have been wrongly used to investigate aircraft accidents but as the stored data cannot contain non-repeatable flight cases the results are often meaningless.

These ‘mimic’ type simulators still have many applications particularly within the training area. Their main advantage is that they present a closed ended teaching situation. That is to say a given action always leads to the same reaction. Thus the trainee can be rehearsed in a particular set of behaviours which lead to a successful outcome. This works well, from the trainer’s point of view, in situations where the aim is to attempt to get the trainee to respond in a proscribed way to a particular stimulus and has thus found many applications in Military and Health and Safety training (Mitra et al. 2013).



Figure 2: An immersive mining engineering simulation at the University of New South Wales.

Figure 2 shows a highly advanced training simulator of this type that is used both to provide simulated underground experience to mining engineering students and demonstrate OH&S issues.

In recent times simulators have started to be introduced that use physics engines to generate the environment and behaviour. This has opened up whole new fields in this area of technology. It is now possible, and commonplace, to fly an aircraft or drive a car in a virtual space at an early stage of its design (Ahmed et al. 2007). This means that the handling and performance can be provided to the design team as they develop their design. Nor is this limited to artefacts, a factory can be simulated at an early stage of conception complete with the human interactions. They behave, however, very differently from the older ‘mimic’ type simulators as they attempt to capture the real variability associated with a real artefact or process. Their fidelity is however limited as they need to operate in real time making processing speed a critical limitation. In training they provide an open-ended solution meaning that the result of a given action is to some extent unpredictable. This presents challenges to trainers they are not always prepared to accept.

Simulation as against modelling

The difference between modelling and simulation is not easy to define though many attempts have been made. These have tended to revolve around the assumption of a basic temporal nature of simulation but this is not satisfactory. In most cases when referring to modelling there is the assumption that mathematical modelling is under consideration. In a mathematical model an attempt is made to relate physical phenomena via mathematical logic. This means that there is no physical relationship involved. In an experimental model an attempt is made to use, a usually, simplified physical model to predict the behaviour of the more complex phenomena under consideration. Simulation lies somewhere between these two methods where the individual processes within the simulation attempt to copy the real physical relationships. What this means in practice is that a mathematical model, as long as properly constructed can produce a precise solution but not a necessarily accurate one. On the other hand simulation lends itself to predictions that are accurate but not precise. In practice it is impossible in any reasonably complex simulation to obtain the precise solution, which means true optimisation is impossible, and thus the methods selected should reflect the desired outcome (Page et al. 2013).

Examples of simulation research

There is a great deal of research being undertaken using this relatively new simulation technology but in this section we will address only two that my research group is involved in.

Complexity

Complex problems present particular difficulties from the point of view of prediction which is the major requirement of

engineering analysis. There are two distinct types of these problems but both lead to a chaotic solution. The simpler of the two leads to a chaotic solution but one in which the results have a statistical relationship to each other. Such problems are often referred to as statistically chaotic problems and there are a range of methods for solving them. In the second class of these problems there is no or at best a very weak statistical relationships between the one result and another. That is to say the past history of results does not allow future results to be predicted. A simple case of this, with only two possible sensible outcomes, is the tossing of a coin. No matter how many times it has been tossed and the history recorded the likely next result remains just as unpredictable. These problems, particularly when more variables are involved, are called deterministically chaotic problems because although the process between input and output is deterministic a solution cannot be predicted with any degree of certainty. Such problems lend themselves to a simulation solution due to its ability to predict accurately. That is to say any generated solution will be a possible solution but not necessarily the one seen in the real world.

An important problem in aerospace engineering is the protection of the occupants of a vehicle in the event of a crash. Helicopters, in particular, present the designer with major problems. It is possible to mitigate possible injuries but that depends on an accurate predictions of the loads applied to the occupants which in turn depends on the impact loads on the aircraft (Pearce et al. 2011, Pei et al. 2014).

While it is not possible to predict the load in any particular case it is possible to fly a flight simulator a large number of times and record the results.

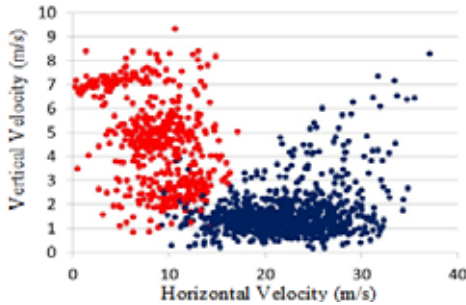

Figure 3. The results of a number of simulations of the impact of a helicopter after engine failure (Pei et al. 2014).

The red points are impacts resulting from engine failures within the area of the flight envelope that are believed to lead to serious harm while the conditions leading to the blue points are deemed less hazardous. It is not possible to find a relationship between the initial conditions and the resulting impact velocities but the data does indicate that there are different zones of results. This gives some basis for confidence in the aircraft's safety envelope.

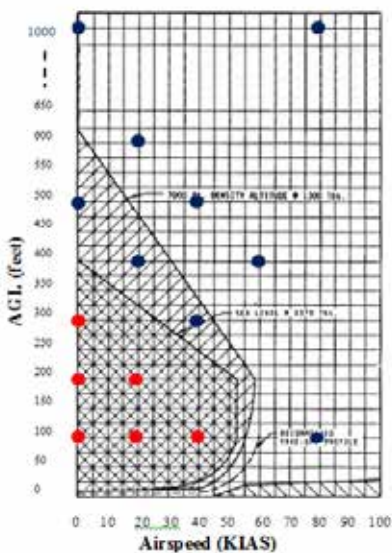

Figure 4. A typical flight safety envelope for a light helicopter (Pei et al. 2014).

The double hatched area is regarded as the values for airspeed and altitude above ground level (AGR) where serious injury is most likely to occur after an engine failure. It should be noted the worst condition is when flying low and slow that part of the plot being known colloquially as 'coffin corner'.

The six initial conditions marked as red spots are within the area of the flight envelope regarded as unsafe and lead to the generation of the cloud of red points in Figure 3. While the blue spots are taken from the less critical region giving rise to the cloud of blue points.

Though the points cannot be directly used for structural load predictions for the helicopter due to any one result being as likely as any other the information can still be used. It should also be noted that any additional tests will result in more points located somewhere within the cloud though their actual location is not predictable. The space which they occupy is, however, significant as any real crash should generate points within this space.

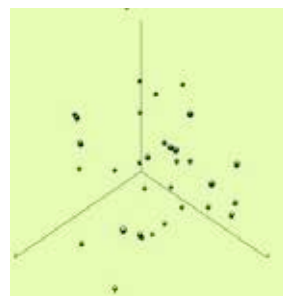

Figure 5. An arbitrary set of points.

Figure 5 shows an arbitrary set of points plotted on three axes. The result is they occupy a three dimensional area of space which can be bounded.

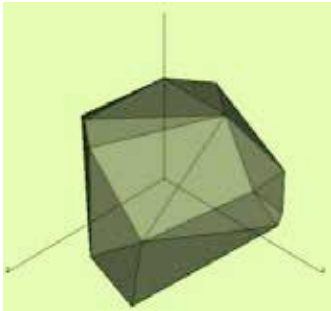

Figure 6. A complex hull.

Figure 6 shows a complex hull constructed so as to form the minimum space encompassing all the points. The Convex Hull Algorithm defines a space within which any real crash should occur. This space can then be searched to identify loads and accelerations that might occur in any real crash. This space can be pseudo-stochastically searched to find data that can then be used to minimise the risk of harm to the helicopter occupants, by design or operational modifications.

Cognitive Relationships

Distributed logic systems offer huge potential advantages. They are far more rugged than centralised systems and, if properly designed, can respond to environmental change much more rapidly. One of the main problems is that they can generate unexpected emergent behaviour. This can of course be a great benefit if the behaviour generated has a positive effect on the mission and thus there are currently significant efforts to predict it. Like the chaos problem, this is very hard to investigate with a mathematical model and may result in unexpected harm if a physical model is used.

One sub-set of these types of systems are swarms and particularly self-organising swarms. Craig Reynolds is often seen as the first researcher to really address this problem with his BOIDS (Reynolds, 1987). He was

able to program agents with just three rules that resulted in complex behavior such as flocking and shoaling. This approach has now found applications ranging from power generation and distribution through industrial management to unmanned aerial systems.



Figure 7. A sea search using self-organising UAVs and a probabilistic algorithm (Sammons 2011).

As the initial condition and the environmental conditions, in a marine search, will change each time a search is undertaken the pattern of the response will vary as will the exact tracks taken by the agents which are thus not predictable.

Another proposed use of this technology, we have investigated, is in the managing of a swarm of spacecraft. There are some real advantages to launching and operating a system based on a number of simple spacecraft rather than one very complex vehicle. The disadvantage, is however that like all spacecraft, the system's life depends of the time before the fuel is exhausted. It is thus important that each agent within the cluster operates such that the swarm remains sound as long as possible if necessary at the expense of an individual agent.

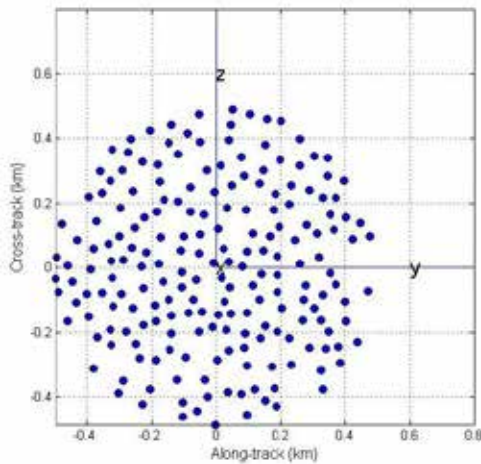

Figure 8. A swarm of spacecraft plotted on a plane (Page et al. 2014).

As each of these spacecraft is orbiting the earth at the same speed, same altitude, but on a different track the swarm will rotate each orbit. Due to disturbances each vehicle will have to use some thrust to fine tune its location. This will in general result in the outer members of the swarm using proportionally more fuel than those at the centre. The mission will be regarded as complete when sufficient vehicles have exhausted their fuel that the swarm can no longer carry out its mission. One solution to this problem is to initiate the mission with different fuel capacities in each agent so all the fuel is exhausted at the same time. This is, however, rather problematic as it depends on accurate predictions of the perturbations the individuals within swarm are likely to encounter. An alternative procedure is for each agent to construct a projected fuel cost map and adjust its behaviour to maximise the useful life of the swarm.

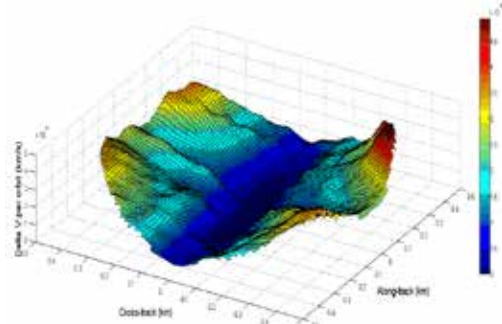

Figure 9. A projected fuel map of a satellite swarm (Page et al. 2014).

Each individual agent can now either change its location within the swarm to reduce or increase its projected fuel use to correspond to its colleagues or sacrifice itself by staying in a high fuel area to prolong the mission in a degraded form. This is a dynamic map based on each agent knowing the fuel state and location of the others. As each decision is enacted or perturbation occurs, the environment changes thus changing the individual agents behaviour and thus that of the swarm.

Initial Rule Selection

There is an inherent weakness in this swarm approach and that is that to initiate the behaviour a set of rules has to be selected. As the behaviour that will emerge is unpredictable at best, the rules that have such a profound effect on the swarm are really only a calculated guess.

One solution to this is to allow the individual agents to develop their own rules. There are two sources of the rules that lead to the collective behaviour of the swarm. The first is related to the physical properties of the agents and can be seen as analogous to nature while the other relates to the much more nebulous control laws that can be seen as analogous to nurture.

The first of these can be treated as a simple rule set that can be modified to improve the swarm behaviour by using evolutionary methods as in the case of a biological system. A set of plausible rules are set determining the physical behaviour of the individual agent. The simulation is then run a number of times and the emergent behaviour is recorded, the rules are then evolved by breeding the most successful agents (Price et al. 2006, Stonedahl et al. 2008).

There are two types of swarms we have investigated; homogeneous, where all the agents are identical and heterogeneous, where each individual is significantly different. The former is relatively easy to evolve as the improvement can be easily followed.

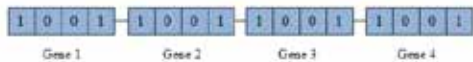

Figure 10. Homogeneous swarm chromosome coding (Tzi-Chieh Chi et al. 2014).

As can be seen the genetic makeup of a heterogeneous agent is rather more complicated.



Figure 11. Heterogeneous Swarm Chromosome Coding (Tzi-Chieh Chi et al. 2014).

In practice while it is relatively easy to show the improvement in evolving rather than arbitrarily choosing as set of rules for a homogeneous swarm we have yet to achieve this for a heterogeneous one.



Figure 12. Simulation of homogenous swarm evolution to success (Tzi-Chieh et al. 2014).

Figure 12 clearly shows how the improvement increases up to about generation 33 after which there is no further improvement. It is expected that a heterogeneous swarm will perform better overall as it can take advantage of ‘wisdom of crowds’ but this is yet to be demonstrated (Galton 1907, Surowiecki 2004).

For the control, nurture, part of the problem improving fitness for purpose involves the agents learning from past events (O’Neil et al. 2014). The method adopted was to utilize neural networks. When these are combined with the physical mutations a somewhat complex picture emerges.

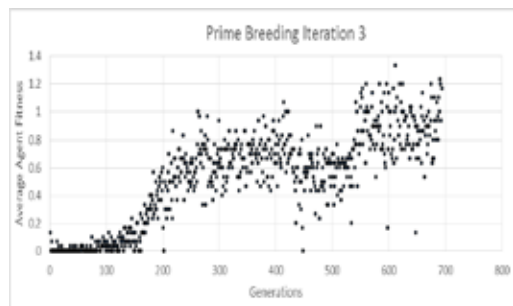

Figure 13. A typical fitness plot (O’Neil et al. 2014).

As can clearly be seen from the plot (Fig. 13) there are instances where the swarm loses fitness while the overall trajectory is toward improvement. There is also much greater scatter in the results for later generations. In practice one would not expect to go far

beyond the 250th generation. At this point the improvement tends to level off. A deeper understanding of these phenomena will be generated by further research.

Metaphysics and simulation

Any new technology offers the possibility of providing the answer to everything. These phenomena can be clearly seen as a response to Newton's Mechanics, the early understanding of thermodynamics and again replayed in the early response to computers. From the simulation point of view it can be clearly dated from the publication of Nick Bostrom's paper in the *Philosophical Quarterly* in 2003 (Bostrom 2003). His thesis was very simple and quite compelling. Sophisticated simulation has now been available for about thirty years and has started to be combined with Virtual Reality capability for the last decade. Full computer based immersion is still quite crude but is improving rapidly and is already providing competition for simulators that combine real and virtual environments. In the most sophisticated of these, possibly the combat flight simulators, the participants express many of the physical and mental responses they would in a real combat aircraft. In other words they have completely, or nearly completely, entered an imaginary world. While we cannot yet get that degree of fidelity in an exclusively computer generated type virtual environment most researchers active in the field believe it will be achieved, the only dispute being how long. So when we can generate a virtual world which we cannot distinguish from the real world we will be expected to generate a large number of them. Nick Bostrom contends as their will be a multitude of simulated worlds as against one real one and an individual cannot distinguish between them the probability is we are all living in a virtual world. This is of course not far removed from Plato's Cave (Plato 360 BCE).

This proposition has generated a number of interesting ideas. The first criticism is that a virtual model of everything would require the same information as sustains reality which would of course be impossible. This argument fails due to the simple fact that one does not have to simulate everything only those parts one interfaces with. A simulator for an Airbus A380 does not have to model Paris when it leaves Sydney to fly there. In fact a simulated Paris only comes into existence when it is needed to provide realism to the simulation by which time the simulated Sydney no longer exists. The basic idea that observation causes existence and the state of that existence is hard to grapple with outside quantum mechanics where physicists appear to have no difficulty.

Another challenge this philosophical view raises is the topic of both space and time. Already, though the fidelity is not yet high I can cross my office and sit by a roaring fire in Tuscany. I can just as easily stand and watch the building of the pyramids in ancient Egypt. If the fidelity was such that to the observer it was impossible to distinguish these simulations from reality how is the experience different from physical or temporal travel?

A number of physicists have tried to determine methods for establishing whether the world as we know it is simply a simulation. One approach has been to look at the high energy cut off of the cosmic ray spectrum (Beane et al. 2012). While they do not discount the possibility of the physical world being a simulation they don't confirm it either. They did raise the interesting prospect at the end of the paper that if this is a simulation then one day we may be able to make contact with The Simulator, a rather theistic suggestion.

One final interesting issue that is raised by this area of enquiry. The apparent three dimensional spaces in the virtual simulation, are generated by a single string of code. This implies that we can generate three dimensional space from a one dimensional bit string. This of course provides a physical model for those physicists promoting concept of the digital universe (Zuse 1969).

Future work

As in any rapidly developing field there are almost too many research opportunities, which makes it hard to predict which will be the most fruitful areas to explore. There are efforts to increase computing capacity but at this stage the problem is how the existing capability should be utilised. The interfaces between the virtual world and a person in the real world is an area that seems to require a great deal of further development along with finding useful niches within technology where application of this capability will make a real difference. What will delay the progress of this capability most dramatically is the lack of researchers working in the field.

Conclusion

The main thrust and aim of this paper is to provide an overview to the reader of some of the progress being achieved in this new field of technology. It is drawing on the computer games industry and the arts to produce a useful tool but due to its newness the field is still confused. By using solid examples related to real engineering problems an attempt has been made to show some of the future possibilities these capabilities will unlock.

Acknowledgments

While the author takes full responsibility for the ideas presented in this paper he is

indebted to his research students Haoyang Cheng, T'zi-Chieh (Monica) Chi, Ian Jones, David O'Neil, Yang Pei, and Phil Sammons without whose efforts little progress would have been made. The author would also like to thank his colleagues for their support, inspiration and expertise in particular, Nathan Kinkaid, Michaelis Michael, John Olsen and Garth Pearce

References

Journal articles:

- Beane S.R., Davoudi Z. and Savage M.J. *Constraints on the Universe as a Numerical Simulation* 2012 High Energy Physics Phenomenology
- Bostrom N., *Are You Living In a Computer Simulation?* Philosophical Quarterly 2003 Vol. 53
- Chi T.-C, Cheng H., Page J. and Ahmed N., *Evolving Swarm of UAV's* Advances in Aircraft and Spacecraft Science 2014
- Galton F. *Vox Populi* Nature Vol.75 1907
- Mitra R. & Saydam S. (2013) *Using Virtual Reality In Tertiary Education*, The International Journal of Technologies in Learning, vol. 19, no. 4, pp. 97–112
- Reynolds C. W. 1987. *Flocks, herds and schools: A distributed behavioral model*. *SIGGRAPH Comput. Graph.*, 21, 25-34.

Books:

- Butler-Bowdon (2010) *Introduction to The Art of War-Sun Tzu* Capstone Publishing U.K.
- Plato. *The Republic Book VII*. Translated Benjamin Jowett The Internet Classics Archive 1994
- Surowiecki J. *The Wisdom of Crowds: Why the Many Are Smarter Than the Few and How Collective Wisdom Shapes Business, Economies, Societies and Nations*. Anchor Books. pp. xv 2005
- Zuse K. (1969) *Rechnender Raum* (space that is computing) Friedrich Vieweg & Sohng 1969

Thesis:

- Sammons P. (2011) *Development of a System in the Loop Simulator for the Control of Multiple Autonomous Unmanned Aircraft*. MA thesis, 2011 University of New South Wales.

Conference Papers:

Chi T.-C., Page J. & Olsen J. (2014) *Simulation of Search and Track Vehicles* SimTecT 2014 Adelaide Australia

O'Neil O., Chi T.-C., Page J. & Olsen J. (2014) *Evolving UAV Search And Rescue Behaviour Using Neural Networks* SimTecT 2014 Adelaide Australia

Page J.R. & Jones I. (2006) *Flight Simulation as an aid to Light Aircraft Design* SimTecT2006 Melbourne Australia

Page J., Olsen J. & Michae M. (2013) *Do engineers need to simulate the real world?* SimTecT2013 Brisbane, Australia

Page J., Cheng H., Chi T.-C. & Kinkaid N. (2014) *Swarm-Based Satellite Constellation Control* Proceedings of the 13th Australian Space Science Conference. National Space Society of Australia, 253-26

Pearce G., Page J. & Kealy J. (2012) *Development of Stochastic Methods for Helicopter Crash Simulation* SimTecT 2012, Adelaide, Australia

Pei Y., Page J. & Pearce G. (2014) *Analysis of Monte-Carlo Simulation on Helicopter Accident Caused by Engine Failure* SimTecT 2014 Adelaide Australia

Price I.C. and Lamont G.B, "GA Directed Self-Organized Search and Attack UAV Swarms," in *Simulation Conference, 2006. WSC 06. Proceedings of the Winter, 2006*, pp. 1307-131

Stonedahl F., Rand W. and Wilensky U., "CrossNet: a framework for crossover with network-based chromosomal representations", Proceedings of the 10th annual conference on Genetic and evolutionary computation, Atlanta, GA, USA, 2008.

John Page left School at 15 to train as fitter then draughtsman in aerospace industry. Through part-time study he gained entry to Hatfield Polytechnic to take a BSc, undertaking industrial training at Hawker Siddley Aviation. Then he undertook an MSc from Cranfield Institute of Technology and research at Brunel and Herriot-Watt Universities. He was appointed as Lecturer/Senior Lecturer at Kingston Polytechnic and then migrated to Australia to take a position at UNSW. John was Head of Department of Aerospace Engineering for ten years and is now the academic in charge of the Simulation and Virtual Engineering Laboratory (SAVE).

Received: 4, August 2014

Accepted: 19, September 2014



A Precision and Bias Study Of Four Masonry Flexural Stress Bond Wrenches

John M. Nichols¹

¹ Construction Science Department, Texas A&M University, College Station, USA

* Corresponding author.
E-mail: jm-nichols@tamu.edu

Abstract

Prior to 1980, one of the constraints in the use of unreinforced and reinforced masonry in earthquake and high wind areas was the relative paucity of design information on the tensile properties of masonry. Wind and earthquake loads induce curvatures in a masonry wall, usually resulting in tensile stress being developed in parts of the wall. If the applied tensile stress field exceeds the capacity of the masonry to resist the stress field the wall will crack and potentially fail, often with fatal results for the inhabitants. Two Victorian researchers, at the Brick Development Research Laboratory in Melbourne in 1980, developed the masonry bond wrench. The bond wrench provides an indirect method of measuring the tensile capacity of masonry in bending. This seminal instrument significantly advanced the ability of scientists to understand the response of masonry to wind and earthquake loads. The purpose of this study is to investigate the precision and bias of four bond wrenches, two of which are commonly used in masonry research and two new wrenches which follow the design concepts of the Italian masonry researchers who study ultralow strength lime based mortars in historic buildings. The principal conclusion, from the research, is that the two international standard wrenches, the Australian Standard AS 3700 Bond Wrench and the ASTM C1072 Bond Wrench exhibit an unacceptable bias and poor precision. The two new wrenches, IB and IUB, based on the conceptual ideas from the Italian research provide a significant improvement on the precision and exhibit only a moderate bias.

Introduction

A bond wrench is used to determine the ability of masonry to resist out of plane loads and is an essential tool for the design of modern thin masonry. This paper reviews the development of four bond wrenches, each modified from the first practical example given by Hughes and Zsebery (1980). The review covers construction issues and the statistical issues of bias and precision of the test results for the four wrenches. The paper presents a brief review of the relevant literature, provides a summary of the key design changes for the four wrenches, outlines the methods used in the research, and provides results with some conclusions.

Literature Review

The first recorded failure of buildings during an earthquake can be attributed to the battle of Jericho as told in the Book of Joshua (Joshua 6:1 – 27, KJV). Clearly the trumpets with a frequency far exceeding the natural frequency of the building could not have caused that level of damage and one can reasonably conclude that the earthquake roar sounded like trumpets to someone who had not experienced a previous earthquake. Clarke (1869) provides an excellent summary of the potential impact of earthquakes on the young colony of NSW, but it is a pity that so much of this data was lost from this early work. A more

complete understanding of the 1804 Parramatta earthquake would assist in judging current risk in Sydney. Cotton (1921) studied the 1919 Kurrajong earthquake, which occurred on the northern outskirts of modern Sydney, although at the time the region was quite remote from the city proper. The 1919 event was an order of magnitude smaller than the 1804 event according to the eyewitness accounts of the events. One can rightly conclude that Sydney is far from immune from earthquakes and likely deaths in a future event from falling masonry.

Nichols (2006) outlined the likely problems in Sydney from a major earthquake, whilst looking at the statistics of earthquake deaths in the world. Fatality counts in earthquakes follow a generalized Poissonian process, which is a statistical method developed by Consul (1989) to study insurance problems.

Gutenberg and Richter (1954) showed that the set of world earthquakes could be subdivided into statistically similar sets for a given region, for a sufficient study time. Gutenberg and Richter (1954), Gutenberg and Richter (1956) further demonstrate the mathematical properties of the statistical distribution related to earthquakes. The fundamental property of this world earthquake data set is that it can be divided by considering various areas as distinct units over sufficient time. Hence an earthquake hazard can be determined for Sydney, Australia. In essence, if ten M5 earthquakes occur in a given period, then a M6 can be anticipated to have occurred in the same period, and so on.... The only difference between Sydney and the Kermadec Islands, which is the most earthquake prone region in the world, is the time period for the ten M5 events, as is true for every location in the world.

The study of deaths in earthquakes shows that the world cannot be divided into a neat array of independent sets based on location, as Gutenberg and Richter had showed for earthquakes. Nichols and Beavers (2008) show that the problem of very large fatal earthquakes is a world issue; there probably will be three events this century with a death toll in the region of 250,000 people, and a possible event up to one million deaths. The three smaller events can only occur in an area with at least 1 million people due to the constraint imposed by ground wave attenuation, population density and building characteristics. There are a strictly limited integer set of urban regions with one million people. This integer set gets rapidly smaller as the size of the event increases. Sydney with a large masonry stock and four million people remains in the set of all possible fatal earthquakes, as does New York as an example.

Donne (1839) wrote “*therefore never send to know for whom the bell tolls; it tolls for thee.*” In this sense one applies Donne’s call to mean, every death in the series of earthquake deaths comes from the one set of people, all of us. We are in this together; we must plan and respond as one unit.

This is one of the few world fatality problems, but it requires an understanding of the world data as one set, somewhat like weather patterns and the now famous butterfly wings problem, Lorenz (1963). The problem is usually attempted to be studied as a region specific issue, which it is not. It is also considered to be an issue of the poorer countries having lower building standards, which it is not. Christchurch demonstrated both points quite well in the last few years in a swarm of events as is well documented by Ingham et al. (2011). In a

series of comments they noted that the event was not expected in Christchurch by the experts, which is common comment heard by the author in reviewing such events. Silent active faults with a return period of 2500 to 10,000 years are killers in the worst possible sense, unexpected, devastating and as the Italians note in a famous proverb always occur in the middle of a snowstorm. Using the snowstorm as a metaphor, one seeks the Achilles heel, which in the case of Sydney can be viewed as masonry veneer in old buildings. One of the major reasons for fatalities in earthquakes is the failure of masonry structures in earthquakes with a magnitude greater than M5. One tragic example is the Italian masonry grade school collapse in 2002 that killed twenty two school children. This was the lowest magnitude earthquake with known fatalities ever as documented by Erbay (2004). These types of single and double storey unreinforced masonry buildings are common in many major urban areas from England, USA, Italy, China and Australia giving just a few sample locations. Understanding how these vulnerable buildings fail in earthquakes is an important step in reducing the death tolls in future earthquakes. Significant work has occurred on understanding the problem, Epperson and Abrams (1989), Erbay (2004), Griffith et al. (2004), Hadjian (1992), but the key to failure is an understanding of the tensile properties of the masonry elements.

Baker (1914) published the first significant treatise on testing masonry and bricks. A test developed at that time determined the tensile stress at failure for mortar samples. Figure 1 shows the test arrangement and the mould specimen as shown by Baker (1914). The problem in using the old mortar test device is that it did not test the bond between the brick and the mortar, which is

often the constraining limit to the flexural strength as shown in recent work by Sugo (2000) completed at the University of Newcastle.

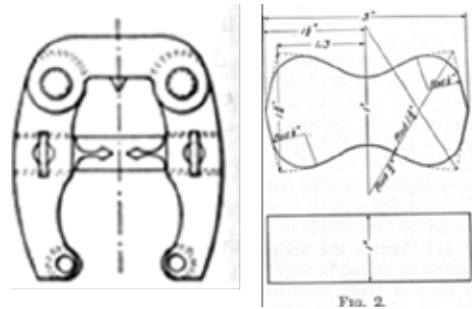

Figure 1: Mortar test device and mould.

Figure 2 shows the simplest beam test used to measure the flexural strength of a masonry pier.

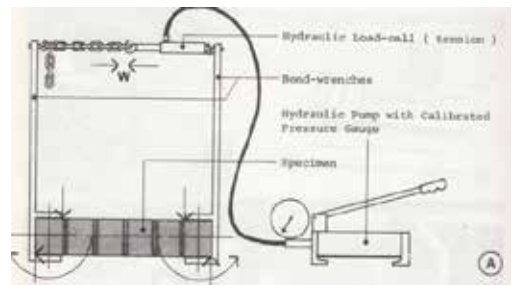

Figure 2: Simple beam test method after Hughes and Zsebery (1980).

The test rig shown in Figure 2 imparts a moment to the masonry prism resulting in a flexural failure in tension on the lower side of the prism. There are several issues with this test method. Each prism yields only one result and it may not be the minimum result due to the secondary moments from the mass of the prism. Establishing straight beams is quite difficult even in a laboratory and the time to manufacture the prisms is lengthy.

Hughes and Zsebery (1980) extended the simple masonry beam test to encompass a

test of every joint in the beam. This device developed by these researchers is now known as the bond wrench. The bond wrench provides a better understanding of the failure strengths for masonry joints, a key step in understanding how to build better masonry. The critical design insight for the bond wrench made by Hughes and Zsembery (1980) was to allow for a two brick prism, with only one joint tested, as shown on Figure 3.

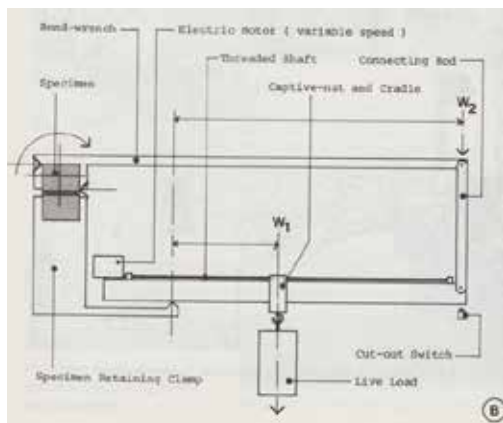

Figure 3: Two brick masonry prism.

The only significant conceptual variation in all subsequent bond wrench designs is to allow for stacked bricks to reduce the wastage of bricks. It is difficult to fathom why any other changes were made to the original design.

Baronio et al. (2003) studied the strength of materials used in a number of Italian buildings. Often this material is centuries old and quite weak, because of the types of pozzalonic material used at the time. The Italian research group developed a balanced bond wrench, which imparted no net bending load on the masonry prisms before the start of the test. By way of contrast the other bond wrench designs all impart a moment at the start of the test. This preload moment, given the low failure loads

of lime based mortars, is a problem in trying to measure ultra-low failure stresses.

Finally, it is a commonly accepted observation that bond strength of 0.1 MPa in masonry veneer significantly reduces fatalities in earthquakes (AS 3700-2001/Amdt 2-2003; 2001). Like most early rules of thumb it provides a measureable standard that can be used to check the performance of masonry in all parts of the world, refer to Abell and Nichols (2003).

Table 1: Member Data.

Number	Started Infants School NSW	Joined Royal Society
1	58	360
2	61	450
3	64	720
4	63	240
5	59	310
6	60	285
7	61	410
8	59	500
9	65	390
10	66	560
Mean	61.6	422.5
Standard Deviation	2.8	143
Variance	7.6	20462

But in comparing results, it is critical to determine if a bias exists between testing devices so that the results are being compared on an equal footing. The standard technique used for comparing the results between different bond wrench tests is to use the Student's *t*-test to statistically compare two sets of numbers representing the measured values. Table 1 shows two

sets of manufactured data. Column 1 holds the entry age in months of ten members of the Royal Society into the NSW Public School system and column 2 holds the age in months for the same members joining the Royal Society.

It is trivial to observe that the Column 1 data could be reported as having a mean of 62 ± 3 months and Column 2 data as having a mean of 420 ± 140 given a reasonable number of significant figures. For the simple hypothesis that the members joined the Royal Society after entry to Infants School, the observation that $420 - 140 \gg 62 + 3$ is the significant answer, given the magnitude of the means and standard deviations or in mathematical terms it is self-evident. The Student's *t*-test developed by a statistician at the Guinness Brewing Company, Miller and Freund (1976), provides a measure of the relative differences between the means allowing for the magnitude of the standard deviations. The critical number is termed the *t*-Stat. Many numerical packages provide a built in function to calculate results for a Student's *t*-test comparison of two data sets. The Student's *t*-test results for the data in Table 1 are shown in Table 2, assuming unequal variances.

The critical number is the $|t\text{-Stat}|$ which is 7.97. The critical case is the one tailed distribution, as except in exceptional circumstances, the starting age at Infants School is going to be less than the age of joining the Royal Society. The probability that the two columns represent the same data is 1 in 88,280 in terms of odds, which is the $P(T \leq t)$ one-tail of 1.1×10^{-5} , confirming the reasonable hypothesis that the Royal Society does not admit infants. The critical *t*-Stat is variable, but for the average problem it has a typical value of

about 2. The bias is the difference in the means and the precision is measured by the standard deviation in the modern setting or the variance originally.

Table 2: Member Data Student's *t*-test

Description	Started Infants School NSW	Joined Royal Society
Mean	61.6	422.5
Variance	7.6	20462.5
Observations	10	10
Hypothesized Mean Difference	0	
Degrees of Freedom	9	
<i>t</i> Stat	-7.97	
$P(T \leq t)$ one-tail	1.13×10^{-5}	
<i>t</i> Critical one-tail	1.83	
$P(T \leq t)$ two-tail	2.27×10^{-5}	
<i>t</i> Critical two-tail	2.26	

Bond Wrench Design

Four bond wrenches have been constructed for this research work. The first and second bond wrenches were to be based on the Australian masonry standard AS 3700-2001/Amdt 2-2003 (2001). This standard provides a conceptual plan for the wrench, rather than a prescriptive design, as used for the ASTM International (2010).

The Indian master's students, who manufactured these two wrenches, lacked the skills to craft the Australian standard wrench in either an unbalanced or a

balanced configuration. The students developed two much lighter wrenches, one balanced and one unbalanced. These wrenches are termed the Indian bond wrenches. The Indian balanced bond wrench is shown in Figure 4.



Figure 4: Indian balanced bond wrench.

Figure 5 shows the schematic plan for the Australian bond wrench from Standards Australia (2001).

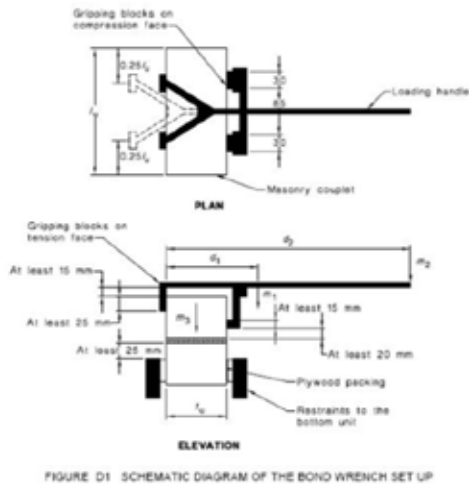

Figure 5: Australian standard bond wrench.

Figure 6 shows the ASTM bond wrench, documented in ASTM International (2013).

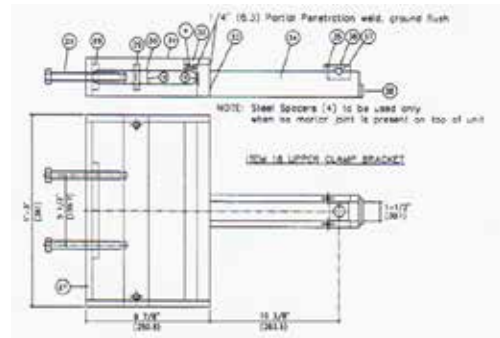

Figure 6: ASTM bond wrench design.

Figure 7 shows the schematic dimensions required to calculate the flexural stress at the point of failure of the specimens. Equation 1 shows the moment, applied to the specimen at the point of flexural failure:

$$M_U = P_1 L_1 + P_2 L_2 \tag{1}$$

where L_1 is the distance from the centre of the brick prism to the centroid of the bond wrench and L_2 is the distance from the applied load to the centre of the brick prism. Table 3 provides the measured mass P_1 for each of the four wrenches. A number has been assigned to each wrench to simplify presentation of the results. Table 4 shows the key dimensions for each of the four wrenches.

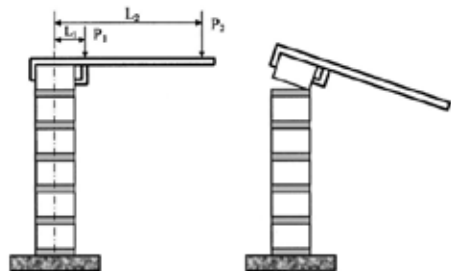

Figure 7: Bond wrench schematic dimensions.

Table 3: Mass of the four wrenches.

Wrench Number	Design Basis	P_f Mass (kg)
1	Indian balanced	6.15
2	Indian unbalanced	6.10
3	ASTM	20.0
4	Australian standard	4.70

Table 4: Dimensions of the four wrenches.

Wrench Number	Length mm	L_1 mm	Length mm	L_2
1	0	660		
2	132	686		
3	363	6		
4	835	203		

Method

Three sets of experimental work have been completed on masonry prisms using this group of wrenches. The first experimental work investigated the difference in bias and precision between the Indian balanced and unbalanced wrenches. This research used an extruded brick from a local Texan brick as shown in Figure 8. The brick had an initial rate of absorption of 0.55 ± 0.04 kg/m²/min, which is within the normally acceptable range for a commercial brick.



Figure 8: Texan extruded bricks.

Mortar was manufactured using a standard mix of six parts of sand to one part of Portland cement, Type A and one part of hydrated lime. The Portland cement and the lime act as the pozzalonic material and the sand is essentially filler between the bricks and pozzalonic material. Abell and Nichols (2003) have studied the properties of this type of mortar. Figure 9 shows a type masonry prism used for the experimental work.



Figure 9: Masonry prisms.

Figure 10 shows the testing arrangement for the balanced bond wrench. This work completed by Chaudhari (2010) and Singala (2010) showed a bias between the results from the two wrenches.

Nichols and Holland (2011) using the same bricks and mortar tested a set of prisms using all four wrenches. This is the second experimental series.



Figure 10: Balanced bond wrench and prism in testing frame.

The third experimental work was by McHargue, who used a Masonry Cement in place of the Portland Type A. This is generally considered to lower the overall flexural strength results, Page (1973), Page (1992).

Failure patterns were observed and recorded on the brick to mortar interface by McHargue. McHargue developed a system for distinguishing between the three basic failure modes. Mode 1 is a Mortar Interface failure, generally considered the weakest failure mode, Mode 2 is the Mortar Bed and Mortar Interface Failure mode and Mode 3 is a Mortar bed failure, generally considered the strongest mode.

The experimental results were analysed using standard statistical techniques as shown in Miller and Freund (1976) and Squires (2001). The critical statistical issues are the precision and the bias in the results. Precision is generally measured as the ratio of the standard deviation to the mean value assuming a normally distributed sample set. This is often termed the coefficient of variation or COV. Masonry testing undertaken on compression specimens, stiffness testing and flexural results typically has a coefficient of variation in excess of

twenty percent, Hendry (2001). The bias is the difference in the mean results using two or more instruments from a common sample set.

Results

The intent for Singala and Chaudhari’s work was to study the difference in the bias and precision between an Australian Standard Bond Wrench and an Australian Standard Bond Wrench that was modified to provide a balanced wrench. Instead these researchers developed much simpler wrenches as shown in Figure 4. Fisher (1971) outlines the standard method developed for experimental design, used for the design of these experimental procedures.

These researchers each tested masonry joints using each wrench to reduce the bias due to experimenter differences in operation of the bond wrenches. The results for the mean failure load for each wrench and experimenter is shown in Table 5.

Table 5: Failure load (m_2) in kilograms

Researcher	Bond Wrench	Mean $\mu \pm \sigma$
I	Unbalanced	21.46 \pm 2.8
II	Unbalanced	21.70 \pm 3.4
I	Balanced	21.83 \pm 2.7
II	Balanced	21.48 \pm 3.4

A Student’s *t*-test analysis shows that there is no statistically significant difference between the results for the unbalanced wrench for the failure load results between the individual experimenters. A similar conclusion applies to the unbalanced to balanced comparison. The COV for the

unbalanced bond wrench is 14.2% and the balanced in 13.8%. These results are exceptionally good for masonry flexural testing. There is not an experimenter induced bias in the results from the testing.

The critical result is the estimated flexural stress at the point of failure as shown in equation (1). The flexural stress at failure for each wrench and experimenter is shown in Table 6.

Table 6: Flexural stress at failure (MPa)

Researcher	Bond Wrench	Mean $\mu \pm \sigma$
I	Unbalanced	0.72 ± 0.09
II	Unbalanced	0.73 ± 0.11
I	Balanced	0.66 ± 0.08
II	Balanced	0.65 ± 0.10

A Student's *t*-test analysis shows a difference that is significant at the 5% confidence level between the balanced and unbalanced stress results. A simple analysis method of taking the balanced and unbalanced stress data into descending sorted order and then performing a regression analysis on the sorted data sets shows that the data is reasonably normally distributed and the least squares ratio between the two data sets is 0.927 ± 0.03 .

Nichols and Holland's results are summarized in Table 7.

Trivially there are no differences in the results for the Australian, balanced and unbalanced wrench at the 5% level, but a Student's *t*-test shows a difference between the ASTM wrench and the other three combined results for the flexural strengths.

Table 7: Flexural stress at failure (MPa)

Wrench	Number of Specimens	Mean $\mu \pm \sigma$
ASTM	8	1.29 ± 0.42
Australian	7	0.88 ± 0.39
Balanced	6	0.83 ± 0.36
Unbalanced	7	0.84 ± 0.46

McHargue tested 330 joints using the ASTM and the Australian Bond wrenches. He used a randomized testing procedure, but used two different but similar brick types, one from Texas and another from Arkansas. The Arkansas brick had an IRA of 0.61 ± 0.1 kg/m²/min. The flexural results are shown in Table 8.

Table 8: Flexural stress at failure (MPa)

Wrench	Test Set	Mean $\mu \pm \sigma$
ASTM	1 Texas Brick	0.29 ± 0.11
Australian	1	0.33 ± 0.12
ASTM	2 Arkansas Brick	0.37 ± 0.11
Australian	2	0.42 ± 0.10

The Student's *t*-test analysis shows that the flexural strength differences are statistically significant at the 5% level for the two test sets.

McHargue's results show an increase in the mean flexural stress with sample number, which suggests either improvements in manufacture or testing had some impact on the results. This result was not observed in the other tests.

The critical statistical value of interest to the design engineer is the Characteristic Flexural Strength for each brick and wrench

combination. The characteristic strength ensures that 95% of all samples have a higher stress value AS 3700-2001/Amdt 2-2003 (2001). This is the value quoted in the specification for the construction of the masonry. A typical minimum value is 0.1 MPa. The characteristic values for the McHargue data are shown in Table 9.

Table 9: Characteristic Flexural Stress (MPa)

Wrench	Test Set	Value
ASTM	1 Texas Brick	0.11
Australian	1	0.15
ASTM	2 Arkansas Brick	0.14
Australian	2	0.19

The ASTM Bond Wrench for the two test sets from the McHargue data show characteristic values of the Flexural strength that are lower than the Australian standard bond wrench test results.

Finally, the ASTM wrench at twenty kilograms is heavy for use by a single individual, compared to the other three wrenches. The ASTM wrench also requires a significantly greater load to develop a comparable stress level compared to the other wrenches. A safety bar had to be fitted to the clamping device shown in Figure 10 to arrest the flight of the ASTM wrench after failure of the masonry prism.

The rather interesting argument from the designers of the main wrenches, ASTM and Australian standard is that their design has allowed for consideration of stress distribution in masonry at the point of failure. The Scottish verdict of **Not Proven** would appear to apply to this assertion,

given the COV of the Indian wrenches in the original testing.

Conclusions

Masonry provides one of the most dangerous elements for humans in an earthquake. Masonry cracks and falls causing crush injuries and death. The 1989 Newcastle earthquake redemonstrated this problem as did the recent tragic event in Christchurch, NZ. Cotton and Clarke clearly demonstrate the potential for a major earthquake in Sydney or some other major urban area. Galadini and Galli (1999) highlight the issue of silent active faults that are hard to identify and allow for in hazard mapping, Christchurch being such an example. One method to reduce the fatality rate in masonry structures in earthquakes is to implement a minimum masonry flexural characteristic strength standard of 0.1 MPa. This standard then forms a simple and relatively inexpensive method of improving quality of masonry produced using this standard.

The simplest techniques for improving the quality of masonry in flexure and to show conformance with the requisite standards is to test the masonry using a bond wrench either as the masonry walls are constructed or by certifying the mason, a technique used after the Newcastle earthquake by some.

Serendipity created the two Indian wrenches and it was not expected that such a simple and inexpensive design could yield consistently precise results with a small bias, and tight precision when compared to the ASTM wrench results. The Indian wrenches are significantly cheaper and easier to build, about \$50 each, when compared to the Australian Standard wrench and the ASTM wrench, which are major undertakings for a small shop. The

Indian wrenches are safer and easier to operate.

It is extremely difficult to make significant changes to major engineering codes of practice, interestingly the key players in the modern development of the bond wrench are friends and meet on a regular basis at major masonry conferences. Yet, there is steep reluctance to let go of an entrenched system, which is really normal human behaviour for better or worse. Considering the very limited number of bond wrenches in the world, probably less than fifty, there is a need for a consistent simple and easily manufactured wrench to be used by all. The point is to develop a common standard that yields precise results, with a known relationship between the results from the equipment to the design requirements for safe masonry buildings and to the other wrenches. Neither the ASTM nor the Australian standard wrenches, the defacto world standard wrenches, meet these criteria of *simplicitate, vilis, subtilis*. As with all things it will take time and energy to push the necessary changes. This paper is a further push in that direction.

Acknowledgements

Thanks to Construction Management students at TAMU, Swapnil Chaudhari, Jatin Singala and Eric McHague completed the masonry testing as part of their research work for their Master of Science in Construction Management degrees. Ben Lawrence, BSc (Construction Science) built the ASTM based wrench.

References

- Abell, A. B. & Nichols, J. M. (2003) *Investigation of the Rheology and Microstructure of Hydrated Lime and Sand for Mortars*.
- AS3700-2001/Amdt 2-2003 (2001) *Masonry Structures*, Standards Australia, Sydney.
- ASTM International (2010) *E518/E518M-10 Standard Test Methods for Flexural Bond Strength of Masonry*, ASTM International, W. Conshohocken PA.
- ASTM International (2013) *C1072-13 Standard Test Method for Measurement of Masonry Flexural Bond Strength*, ASTM International, W. Conshohocken, PA.
- Baker, I. O. (1914) *Treatise on Masonry Construction*, 10th edn., Wiley, New York, xiv+745.
- Baronio, G., Binda, L., Tedeschi, C. & Tiraboschi, C. (2003) Characterisation of the materials used in the construction of the Noto Cathedral, *Construction and Building Materials*, 17, 8, 557-571.
- Chaudhari, S. (2010) *Comparative Analysis between a balanced and unbalanced bond wrench*, Master of Science (Construction Management) thesis, Texas A&M University, TAMU.
- Clarke, W. (1869) On the causes and phenomena of earthquakes, especially in relation to shocks felt in New South Wales and in other provinces of New South Wales, *Proceedings and Journal of the Royal Society of New South Wales*, 2, 51-86.
- Consul, P. C. (1989) *Generalized Poisson Distributions: Properties and Applications*, Dekker, NY.
- Cotton, L. A. (1921) The Kurrajong Earthquake of August 15, 1919, *Proceedings and Journal of the Royal Society of New South Wales*, 55, 83-104.
- Donne, J. (1839) *The Works of John Donne vol III*, John W. Parker, London.
- Epperson, G. S. & Abrams, D. P. (1989) *Non-destructive evaluation of masonry buildings*, ATC, Urbana.
- Erbay, O. O. (2004) *A methodology to assess seismic risk for populations of unreinforced masonry buildings* Ph.D. thesis, University of Illinois at Urbana-Champaign, Urbana, IL, USA.
- Fisher, R. A. (1971) *The Design of Experiments*, Macmillan, London.
- Galadini, F. & Galli, P. (1999) The Holocene paleoearthquakes on the 1915 Avezzano earthquake faults (Central Italy): implications for active tectonics in the central Apennines, *Tectonophysics*, 308, 143-70.

- Griffith, M. C., Lam, N. T. K., Wilson, J. L. & Doherty, K. (2004) Experimental Investigation of Unreinforced Brick Masonry Walls in Flexure, *Journal of Structural Engineering*, 130, 3, 423-432.
- Gutenberg, B. & Richter, C. F. (1954) *Seismicity of the Earth and Associated Phenomena*, Princeton University Press, Princeton New Jersey, 273 p. illus., maps, profiles. 28 cm.
- Gutenberg, B. & Richter, C. F. (1956) Earthquake Magnitude, Intensity, Energy and Acceleration, *Bulletin of the Seismological Society of America*, 46, 105-143.
- Hadjian, A. H. (1992) *The Spitak, Armenia Earthquake - Why so much damage?*, 5-10.
- Hendry, A. W. (2001) Masonry walls: materials and construction, *Construction and Building Materials*, 15, 8, 323-330.
- Hughes, D. M. & Zsembery, S. (1980) *A Method of Determining the Flexural Bond Strength of Brickwork at Right Angles to the Bed Joint*, 105-115.
- Ingham, J. M., *Emails on the Christchurch Earthquake Deaths* (2011), Auckland.
- Ingham, J. M., Biggs, D. T. & Moon, L. M. (2011) How did unreinforced masonry buildings perform in the February 2011 Christchurch earthquake., *The Structural Engineer*, 89, 6.
- Lorenz, E. N. (1963) Deterministic Nonperiodic Flow, *Journal of the Atmospheric Sciences*, 20, 130-141.
- Miller, I. & Freund, J. E. (1976) *Probability and statistics for engineers* 2nd. edn., Prentice-Hall, Englewood Cliffs, N.J., ix, 529 p. : ill. ; 24 cm.
- Nichols, J. M. (2006) The Rule of Unintended Consequences, Sydney's Water Supply Strategy, *Built Environment*, 32, 4, 434-446.
- Nichols, J. M. & Beavers, J. E. (2008) World Earthquake Fatalities from the Past -- Implications for the Present and Future, *Natural Hazards Review*, 9, 4, 179-189.
- Nichols, J. M. & Holland, N. L. (2011) *A Comparative Study of Balanced Bond Wrench Testing and Unbalanced Bond Wrench Testing*.
- Page, A. W. (1973) *Structural Brickwork - A Literature Review*, Department of Civil Engineering, University of Newcastle,, Newcastle.
- Page, A. W. (1992) The design, detailing and construction of masonry - the lessons from the Newcastle earthquake., *Australian Civil Engineering Transactions*, 34, 4, 343-53.
- Singala, J. Y. (2010) *Sensitivity Analysis of Bricks using the Bond Wrench Apparatus*, Master of Science (Construction Management) thesis, Texas A&M University, College Station.
- Squires, G. L. (2001) *Practical Physics*, 4th edn., Cambridge University Press, Cambridge ; New York.
- Sugo, H. O. (2000) *Strength and microstructural characteristics of brick/mortar bond* Ph.D. thesis, University of Newcastle, Newcastle, 1 v., 42 plates : ill. ; 30 cm.

John Nichols graduated from Belmont Infants School in 1964, completing further study in Pure Mathematics at ANU and Civil Engineering at the University of Newcastle. He has taught at the University Newcastle, University of Illinois at Urbana Champaign, Curtin University and Texas A&M University. He won an engineering excellence award from the Institution of Engineers in 1991 for the repairs to Saint Andrews Church, Newcastle resulting from the 1989 Newcastle earthquake, whilst working for the consulting engineering company, Sinclair Knight Merz.

Received: 29, April 2014

Accepted: 29, July 2014



Obituary

Dr. Daniel John O'Connor

13 December 1927 – 21 April 2014.



Born at Albert Park, Melbourne, the second child of Daniel and Kathleen O'Connor, he grew up in a workingman's cottage. His childhood during the depression years 'paved the way for later life: he never wasted anything and his home later became filled with pieces that might come in handy later, together with souvenirs from around the world' [Obituarist at Dr. O'Connor's funeral service].

Although claiming to have learnt nothing in primary school, nonetheless he gained a scholarship to St. Colman's College Fitzroy, then later to Parade College East Melbourne and St. Kevin's Toorak. His school ability led to a Free Place at Melbourne University and a Bursary to Newman College there.

From his youth he always involved himself in life around him – socially, politically and academically, notably in the Newman Society and as a Student Representative Councillor.

For someone with such broad and time-consuming interests, that might have

diverted him from study, Dan's academic record was impressive. He completed B.Sc (Chemistry, Physics & Engineering) in 1948, M.Sc (Mineral Chemistry) 1950 and PhD (Mineral Chemistry) 1954, both the Masters and Doctorate studies being supported by Scholarships.

Following his PhD he was awarded a Junior Harwell Fellowship to research at Harwell (UK), travelling there 'without a penny', but on a free first class ticket by ship with his new bride, Margaret Maloney. Some three and a half years at Harwell saw Dan's research abilities bloom.

Returning to Australia in October 1957 he became successively Research Officer and Senior Researcher at the Australian Atomic Energy Commission, Lucas Heights, southwest of Sydney, until December 1961, also doing some part-time Chemistry lecturing, 1959-1960 at the University of New South Wales.

Between February 1961 and August 1962 he was Research and Development Officer at Taubmans Industries, Sydney, before beginning a long association (to June 1983) at Colonial Sugar Research, which proved an important centre for the company, having at its peak 150 researchers, 40 of them graduates. Between April 1980 and June 1983 Dan was Director of Research there. In 1976 he had a brief stay as Visiting Research Fellow at the University of Cologne, the first of many invited visits to numerous overseas research bodies.

From July 1983 he had a series of short appointments, at the Energy Authority,

NSW; Senior Research Fellow Chemical Engineering, University of Sydney; Manager Research and Development at Unisearch (University of New South Wales); and between January 1989 and June 1992 was Executive Director of ANZAAS, and Editor of *Search*.

In 1966 Dan returned to academic pursuits, gaining a B.Ec at the University of Sydney for work on Government and Industrial relations, and an M.Ec in 1968 on Science and Public Policy. In 1974 he studied aspects of Law through the Supreme Court Board, but did not follow this up further.

The nature of Dan's work saw much of his research work appear only as confidential Company and Government reports. Between 1955 and 1957 his Harwell work produced seven individual and five joint reports. His work at Lucas Heights produced six individual and five joint reports. His long sojourn at CSR produced 90 individual and 45 joint reports.

Nevertheless, in the public domain he was author or joint author of 40 publications in journals such as *Nature*, *The Australian Journal of Science*, *The Journal of Chemistry*, *The Australian Journal of Chemistry*, *Inorganic and Nuclear Chemistry*. Two major publications were his sole authored *Alumina Extraction from Non-Bauxitic Materials* (Aluminium-Verlag GmbH, 1988, 461pp) and the jointly authored Ashburn, A.G., Dawson, J.K., O'Connor, D.J. Waldron, M.B. & Walton, G.N. (eds), *Glove boxes and Shielded Cells for Handling Radioactive Materials* (Butterworths, 515 pages, 1988).

At various times he was President of the Sydney Branch of the Melbourne University Alumni Society and he and his wife funded a scholarship for Newman College,

Melbourne University. He was an active member of many societies including the Clean Air Society, Royal Australian Historical Society, Australian-Japan Society.

Dan was a relatively late joiner of the Royal Society, but when he did he became fully engaged, serving on the Council from 1994. He was Treasurer (April 1995-March 1998), elected President, 1998-1999. His presidential address was '*The Australian Republic and the Royal Society of New South Wales*' published in the Society's Journal. In these years he was also involved in the summer Schools for Senior Secondary Students held at Royal Prince Alfred Hospital and at the Australian Nuclear Science and Technology Organisation. The Council awarded him the Society's medal in 1999.

A fan of his beloved Sydney Swans, Dan himself kept fit with tennis, squash and skiing and ran in the Sydney City to Surf seventeen times (until 1999).

Despite his major research Dan was regarded by many friends as somewhat impractical, one noting that Dan 'had little room for practical and everyday things. He often had a bandaid over his forehead from walking into a door, hitting a car boot roof'. His wife of over sixty years commented with a wry smile 'it was ever thus'.

Dan O'Connor was given a fond farewell by his family (wife, daughter Nicola and four grandchildren), local and interstate visitors at the Catholic Church, Northbridge, Sydney, followed by a wake at the Royal Sydney Yacht Squadron, Kirribilli.

David Branagan, from personal knowledge, and information from Margaret O'Connor

Amendments to a previously published paper in this Journal

The Russian Expedition's Sydney Visit in 1820 and some Forgotten Blue Mountains Names

Vol. 143, p.1-28, 2010

David F. Branagan

I am grateful to Robin Walsh, Honorary Associate, School of Modern History, Macquarie University, who visited St. Petersburg in 2005, for pointing out (2nd April, 2014) several errors and omissions in the paper named above.

Page 7, footnote 15. 'The driver is not identified' is **incorrect**. He was, in fact, John Fuller, rewarded by Governor Macquarie for his assistance by payment of £11 from the Police Fund, as noted in the *Sydney Gazette*, 29 July 1820, p. 2.

P. 21, footnote 21. It is suggested that Campbell's Cataract [presently named Wentworth Falls] 'was named by Macquarie for his Secretary John Thomas Campbell (c. 1770-1830), brother of his second wife Elizabeth' (this error was taken from a reference in Hugh Speirs, p. 40, referenced in the paper).

However this Campbell was NOT related to Elizabeth Macquarie, but was from Northern Ireland, and recruited by Macquarie at Cape Town when Macquarie was *en route* to Sydney (*Australian Dictionary of Biography*, vol. 1).

I also note that on Page 1, column 1: The ships, under the command of Mikhail Nikolaevich Vasiliev, were NOT 'the northern party of the exploring expedition led by Admiral Bellingshausen', but an independent expedition.

Received: 11, August 2014

Accepted: 11, August 2014





Proceedings of the Royal Society of New South Wales

The 2014 programme of events – Sydney

The venue for Society meetings was the Union University and Schools Club, 25 Bent Street, Sydney unless noted otherwise.

Wednesday 6 February 2014

1218th Ordinary General Meeting - Scholarship Presentations

Mr John Chan (Pharmacology, University of Sydney)

Ms Jessica Stanley (Chemistry, University of Sydney)

Mr Jiangbo (Tim) Zhao (Advanced Cytometry Labs, Macquarie University)

Thursday 29 February 2014

Joint Meeting with Australian Academy of Forensic Sciences

Searching for clues: unmasking art fraud and fraudsters

Assoc. Professor Robyn Sloggett

Thursday 27 February 2014

The Four Societies Lecture

Questions about power in NSW

Professor Mary O’Kane, NSW Chief Scientist and Engineer

Venue: Hamilton Room, Trade & Investment Centre,
Industry & Investment NSW
Level 47, MLC Centre, 19 Martin Place, Sydney

The Four Societies Lecture was presented in conjunction with the Nuclear Engineering Panel of the Sydney Branch of Engineers Australia, the Australian Nuclear Association and the Australian Institute of Energy.

Wednesday 5 March 2014

1219th Ordinary General Meeting

Big data knowledge discovery: machine learning meets natural science

Professor Hugh Durrant-Whyte FRS, CEO of NICTA

Thursday 3 April 2014
Annual General Meeting

Dr Donald Hector was re-elected President of the Society.

1220th Ordinary General Meeting

The Jameson Cell

Laureate Professor Graeme Jameson AO

Wednesday 7 May 2014

Annual Dinner, 1221st Ordinary General Meeting

Royal Society of NSW 2014 Distinguished Fellows Lecture and presentation of Awards

The Royal Society of NSW 2014 Distinguished Fellows Lecture was presented by Professor Barry Jones AC Dist FRSN.

The President, Dr Donald Hector, presented the Society's 2013 awards. The Edgeworth David Medal was presented to Assoc. Prof David Wilson, for his outstanding work on modelling HIV/AIDS and using this information to develop treatment and prevention strategies. Prof. Michelle Simmons Dist. FRSN was awarded the Walter Burfitt Medal and Prize and Professor Brien Holden AM was awarded the James Cook Medal for his work in treating myopia (a leading cause of preventable blindness), particularly in developing world countries. The Clarke Medal was awarded to distinguished geologist William Griffin, who was overseas and unable to attend.

Tuesday 13 May 2014

Joint meeting with Australian Institute of Physics and the Royal Australian Chemical Institute

The Australian Synchrotron in the International Year of Crystallography

Wednesday 4 June 2014

1222nd Ordinary General Meeting

Lessons learnt? The Global Financial Crisis six years on

Professor Robert Marks, FRSN

Wednesday 2 July 2014

1223rd Ordinary General Meeting

What causes MS? The impact of the genetic revolution

Professor Graeme Stewart AM

Wednesday 6 August 2014

1224th Ordinary General Meeting

Science: essential education and the role of the Australian Academy of Science
Emeritus Scientia Professor Eugenie Lumbers AM Dist FRSN FAA

Wednesday 3 September 2014

1225th Ordinary General Meeting

The Fourth Dimension and Beyond: the paradox of working in unimaginable worlds
Scientia Professor Ian Sloan AO FRSN

Wednesday 1 October 2014

1226th Ordinary General Meeting

Australia's most spectacular environmental rehabilitation project: Phillip Island, Pacific Ocean
Dr Peter Coyne

Wednesday 5 November 2014

1227th Ordinary General Meeting

A Drop of Optics
Dr Steve Lee and Dr Tri Phan, joint winners of the 2014 ANSTO Eureka Prize
for Innovative Use of Technology

Thursday 20 November 2014

The Liversidge Research Lecture 2014

Recent Studies on the Total Synthesis of Natural Products and Related Systems
Professor Martin Banwell, Research School of Chemistry, Institute of Advanced
Studies, Australian National University, Canberra

Professor Banwell is an organic chemist and is one of Australia's most
accomplished researchers into the synthesis of complex organic compounds.

The Liversidge Research Lecture is presented by Royal Society of NSW, in
conjunction with the University of Sydney and the Royal Australian Chemical
Institute.

Venue: Lecture Theatre 4, School of Chemistry, Eastern Avenue, University of
Sydney

Wednesday 3 December 2014

1228th Ordinary General Meeting

RSNSW 2014 Jak Kelly Award Presentation and Society's Christmas Party

Awarded to Ms Lhin Tran, a third-year PhD student at the Centre for Medical
Radiation Physics (CMRP) at the University of Wollongong.

Presented by Mrs Irene Kelly, widow of Professor Kelly.

Tuesday 9 December 2014

Dirac Lecture

The Beauty and Serendipity of Blue Sky Research

Professor Serge Haroche, Head of the Collège de France, Paris

Professor Haroche (jointly with David J. Wineland) was awarded the 2012 Nobel Prize for Physics for ground-breaking experimental methods that enable measuring and manipulation of individual quantum systems, for their work on understanding the photon.

The Dirac Lecture was presented by the University of New South Wales, in conjunction with the Royal Society of NSW and the Australian Institute of Physics.

Venue: Tyree Room, John Niland Scientia Building, University of New South Wales





Proceedings of the Royal Society of New South Wales

The 2014 programme of events – Southern Highlands Branch

The usual venue for Southern Highlands branch meetings is the Performing Arts Centre, Chevalier College, Bowral.

Thursday 20 February 2014 at 6:30 pm.

Forensic Entomology

Dr James Wallman

Thursday 20 Mar 2014 at 6:30 pm.

Building Sustainability

Professor Paul Cooper

Thursday 17 April 2014 at 6:30 pm.

Using lasers to create the coldest stuff in the universe

Professor Ken Baldwin

Thursday 15 May 2014 at 6:30 pm.

The relationship between baroque music and senile dementia

Dr Chistian Heim

Thursday 19 June 2014 at 6:30 pm.

The Good Life

Hugh MacKay

Thursday 17 July 2014 at 6:30 pm.

The Royal Society and Gulliver's Travels

Emeritus Professor Clive Probyn

Thursday 14 Aug 2014 at 6:30 pm.

Green materials and recycling end-of-life polymers in steelmaking

Scientia Professor Veena Sahajwalla

Thursday 16 Oct 2014 at 6:30 pm.

Higgs-Boson and CERN

Professor Kevin Varvell

Thursday 6 Nov 2014 at 6:30 pm.

Bees in the food chain – economy and threats

Dr Madeleine Beekman

Thursday 20 Nov 2014 at 6:30 pm.

Genes and their relationship with Epigenes

Dr Catherine Suter





The Distinguished Fellows Lecture 2014

Wednesday, 3 April 2013

Evidence, opinion and interest – the attack on scientific method

Professor Barry Jones AC Dist FRSN FAA FTSE FASSA FAHA



Professor Barry Jones delivering the Distinguished Fellows Lecture.

The Society was proud to have Professor Barry Jones present the Fellows Lecture on Wednesday, 7 May 2014. Professor Jones is the only person to have been elected a Fellow of all four of Australia's National Academies.

Science and research generally are given disturbingly low priority in contemporary public life in Australia, although medical research and astronomy may be exceptions. Scientists, especially those involved with climate change, or the environment, have come under unprecedented attack, especially in the media, and the whole concept of scientific method is discounted, even ridiculed. In a complex world, people seem to be looking for simple solutions that can be

expressed as slogans, and the quality of public debate on scientific issues has been trivialised, even infantilised. The controversy on anthropogenic global warming (AGW) has been conducted at an appalling level on both sides of politics. (Debates on refugees and taxation have been conducted at a similar level.) Vaccination, fluoridation and even evolution are hotly, but crudely, disputed in some areas. Despite Australia's large number of graduates (more than 4,000,000), our 38 universities and intellectual class generally have very limited political leverage and appear reluctant to offend government or business by telling them what they do not want to hear. Universities have become trading corporations, not just communities of scholars. Their collective lobbying power seems to be weak, well behind the gambling, coal or junk food lobbies and they become easy targets in times of exaggerated budget stringency. Paradoxically, the Knowledge Revolution has been accompanied by a persistent 'dumbing down', with ICT reinforcing the personal and immediate, rather than the complex, long-term and remote. In a democratic society such as Australia, evidence is challenged by opinion and by vested- or self-interest. Australia has no dedicated Minister for Science with direct

ownership / involvement in promoting scientific disciplines. If every vote in Australian elections is of equal value, does this mean that every opinion is entitled to equal respect? It is easy to categorise experts as elitists, and out of touch. There are serious problems in recruiting science teachers, and numbers of undergraduates in the enabling sciences and mathematics are falling relative to our neighbours. In an era of super-specialisation, many scientists are reluctant to engage in debate, even where their discipline has significant intersectoral connections. Science has some outstanding Australian

advocates, Gus Nossal, Peter Doherty, Ian Chubb, Fiona Stanley, Robert May, Brian Schmidt, Ian Frazer, Mike Archer among them, but they lack the coverage that is needed and that they deserve. There is a disturbing lack of community curiosity about our long term future, with an apparent assumption that consumption patterns will never change.

(The full text of Professor Jones' lecture was published in vol. 147, nos. 451 & 452, pp. 2-10.)





The Liversidge Research Lecture 2014

Thursday, 20 November 2014

Recent studies on the total synthesis of natural products and related systems

Professor Martin Banwell

Research School of Chemistry, Institute of Advanced Studies, Australian National University, Canberra

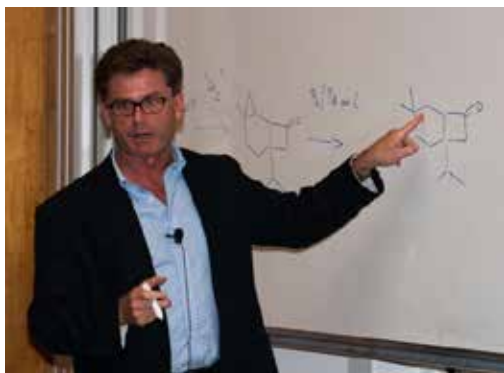

Professor Martin Banwell delivering the Liversidge Research Lecture 2014.

The Liversidge Research Lecture 2014 was delivered by Professor Martin Banwell at the University of Sydney on Thursday, 20 November 2014. Professor Banwell is an organic chemist and is one of Australia's most accomplished researchers into the synthesis of complex organic compounds. In this year's Liversidge Research Lecture, he described work that has been done in his group over a number of years to synthesise materials that have wide-ranging applications, especially as pharmaceuticals.

The starting point for his work is a family of organic chemicals called arenes. These are substances based on a structure of six carbon atoms arranged in a ring, with each carbon atom having a hydrogen atom attached – this substance is known as benzene. Some of the hydrogen atoms can be replaced by other substituents, for example, instead of one of the hydrogen atoms, methyl, bromine, chlorine, trifluorocarbon, hydroxyl, carboxyl etc. groups can be substituted. These can then be used as building blocks, using a variety of synthetic pathways, to make much more complex substances.

Until quite recently, many of these syntheses were done using a variety of chemical reactions that have been developed by organic chemists over the last 150 years. One of the problems that arises with this approach is that substances with the same chemical formula can have different shapes. For example, substances can have the same chemical formula but be mirror images of each other, in much the same way as the

right-hand is the mirror image of the left-hand – these are called enantiomers. Often, one enantiomer will have little physiological effect in comparison to the other. In the last 15 years or so, genetically-modified organisms have been developed that allows synthesis of these substances that favours production of the biologically-active enantiomer.

Professor Banwell described his work to develop synthetic pathways, starting with the simple substances described above and reacting these with genetically modified *e. coli* to produce an arene with two adjacent hydroxyl groups, in addition to the other reactive site. This results in an intermediate that allows a great variety of subsequent synthetic pathways, allowing synthesis of a very large number of biologically active substances. Two examples of these are vitamin C and the influenza drug Tamiflu.

Professor Banwell went on to describe a complex sequence of reactions that has enabled his group to synthesise a substance called Ribisin C, the substance that, at very low concentrations, appears to have a marked effect on the stimulating neurite growth in PC12 cells. (Neurites are projections that grow from neurons (nerve cells) as they develop and PC12 cells are particular type of rat neuron that is used in medical research.) It is hoped that this research work may lead to new treatments for neurological diseases and damage to the nervous system.

Professor Banwell's group is also working on novel pathways for making codeine, an opioid that is currently derived from opium poppy production. A synthetic pathway could, potentially, lead to a much less expensive production process for opiates.





The Dirac Lecture and Medal Presentation 2014

Tuesday, 9 December 2014

The Beauty and Serendipity of Blue Sky Research

Professor Serge Haroche
Head, Collège de France, Paris



Nobel Laureate Professor Serge Haroche illustrated the long road from fundamental discoveries to technological innovations by a few examples taken from his own field of research – atomic and optical physics. He reflected on the dangers that blue sky research faces in our uncertain global world and explained why it is essential to protect it and to make it thrive, in spite of the present economic difficulties.

Professor Haroche is a French physicist who was awarded the 2012 Nobel Prize for Physics jointly with David Wineland for “ground-breaking experimental methods that enable measuring and manipulation of individual quantum systems”, a study of the particle of light, the photon. Since 2001 he has been a Professor at the Collège de France and holds the Chair of Quantum Physics. He is a member of the Société Française de Physique, the European Physical Society and a fellow and member of the American Physical Society.

The Dirac Lecture is held annually by the University of NSW in conjunction with the Royal Society of NSW and the Australian Institute of Physics, NSW Branch.



Royal Society of New South Wales Awards for 2014

Award	Recipient
Clarke Medal	Professor Robert F. Park
Edgeworth David Medal	Associate Professor Richard Payne
James Cook Medal	Scientia Professor Martin Green
RSNSW Scholarships	Melanie Laird
	Ruth Wells
	Stephen Parker
Jak Kelly Award	Linh Tran

Articles from the award winners will be published in the 2015 issues of the Society's Journal.



The Clarke Medal

Professor Robert F. Park **University of Sydney, Plant Breeding Institute**

The Clarke Medal was established to acknowledge the contribution by the Rev William Branwhite Clarke MA FRS FGS, Vice-President of the Royal Society of New South Wales from 1866 to 1878. The Medal is awarded annually for distinguished work in a natural science done in Australia and its Territories.

The Medal is awarded by rotation in the fields of geology, botany and zoology. This year's award is in the field of botany in all its aspects.

The Clarke Medal for 2014 in the field of Botany has been awarded to Professor Robert Park of the University of Sydney.

Professor Robert Park is an international leader in plant pathology and genetics, who focuses particularly on rust fungi that infect crop plants in agriculture. He has made major contributions to the global effort to control these diseases using genetic approaches, especially in cereal rusts. Working across a number of related areas, Professor Park has made crucial research findings in the genetics of resistance, pathogenic and molecular variability in rust pathogens, and more recently, functional genomics of host-pathogen interactions. By helping to safeguard the world's primary cereal crops, Professor Park is making an enormous contribution to national and global food security, the economic viability of agricultural production, and the ecologically sustainable use of Australia's natural resources. A recent count of commercial wheat cultivars in Australia indicated that Professor Park's pre-breeding genetics work contributed to 51 of the 150 or so that are listed.

The 2014 Clarke Medal in the field of Botany is a fitting recognition of Professor Robert Park's huge impact and contributions to plant science.

The Medal will be presented at the Annual Dinner of the Royal Society in 2015.





Edgeworth David Medal

Associate Professor Richard Payne University of Sydney, School of Chemistry

The Edgeworth David Medal, established in memory of Professor Sir Tannatt William Edgeworth David FRS, a past President of the Society, is awarded for distinguished contributions by a scientist, under the age of 35, having accomplished the majority of his or her work in Australia.

The conditions of the award of the Medal are:

- The recipient must be under the age of thirty-five years at 1st January, 2013.
- The Medal will awarded be for work done mainly in Australia or its Territories or contributing to the advancement of Australian science.

The 2014 Edgeworth David Medal has been awarded to Associate Professor Richard Payne of the University of Sydney.

Associate Professor Payne has achieved an extraordinary amount over his short scientific career thus far and this has led to his recognition as one of Australia's leading chemists. His research is focused on using the tools of organic chemical synthesis to engineer new molecules targeted towards specific problems in biology and medicine. A/Prof Payne's research can be divided into two distinct areas. The first of these is anti-infective drug discovery, with a strong focus on the design and development of new anti-tuberculosis and anti-malarial agents. He has developed a number of tuberculosis (TB) drug leads which target novel enzyme targets, an example being the development of inhibitors for an essential cell wall lipase in *Mycobacterium tuberculosis*. The second field that A/Prof Payne has made important contributions to is the development of novel strategies for the synthesis of carbohydrate-modified peptides and proteins for applications in therapeutics and materials research, including cancer vaccines and diagnostics and antifreeze biomolecules.

Associate Professor Payne is an exceptional young scientist working in an exciting field where he is already acknowledged as a world leader, and he is a worthy winner of the Edgeworth David Medal for 2014.

The Medal will be presented at the Annual Dinner of the Royal Society in 2015.





The James Cook Medal

Scientia Professor Martin Green AM FTSE FAA FRS UNSW, Australian Centre for Advanced Photovoltaics

The James Cook Medal was established in 1947 with funding by Henry Ferdinand Halloran. Halloran, who had joined the Society in 1892 as a 23 year-old, was a surveyor, engineer and town planner. He did not publish anything in the Society's Journal but he was a very enthusiastic supporter of research. Halloran funded what were to become the Society's two most prestigious awards, the James Cook Medal and the Edgeworth David Medal, the latter being the medal for young scientists. The James Cook Medal is awarded at intervals for outstanding contributions to science and human welfare in and for the Southern Hemisphere.

The 2014 James Cook Medal has been awarded to Scientia Professor Martin Green of the University of New South Wales.

Professor Martin Green, often described as “the father of modern photovoltaics”, is Director of the acclaimed Australian Centre for Advanced Photovoltaics at The University of New South Wales. A global leader in the development of alternative energy technology, the real world outcomes of his research have revolutionised solar cell technology and the associated industry. Martin Green has made unparalleled contributions to solar cell design, uptake of photovoltaics technology and to the realisation of its benefits. His fundamental research achievements, as well as his incitement of major investment in the technology, have resulted in vastly improved cell performance and radically reduced production costs. Key concepts Green introduced that are now standard in high efficiency solar cell design include small area contacts to control detrimental impacts, thin oxide layers in his 25% efficient cells, inversion layers under such oxides, moderate doping to control Auger impacts, non-ergodic light-trapping using macroscopic surface texture, electroluminescence to monitor cell quality, as well as invention of the successive generations of devices exploiting these features which have broken the world record for efficiency at every stage of development. Scientia Professor Green, as the James Cook Medal citation reads, has clearly made “outstanding contributions to science and human welfare in and for the Southern Hemisphere”.

The Medal will be presented at the Annual Dinner of the Royal Society in 2015.





Royal Society of New South Wales Scholarships The Jak Kelly Award

The Royal Society of NSW Scholarships are funded by the Society in order to acknowledge and support outstanding achievements by early-career individuals working towards a higher research degree in a science-related field.

The Jak Kelly Award is awarded jointly with the Australian Institute of Physics to the best PhD student talk presented at a joint meeting with the AIP.

Three Royal Society of NSW scholarships were awarded in 2014, to Melanie Laird of the University of Sydney, Ruth Wells of the University of Sydney and Stephen Parker of the University of New South Wales.

The Jak Kelly Award was made to Linh Tran of the University of Wollongong.

Melanie Laird (University of Sydney, School of Biological Sciences)

Melanie Laird, a University of Sydney Medallist, is in her second year of a PhD under the supervision of Professor Michael Thompson, studying reproduction in marsupials. The main aim of her project is to identify the uterine changes involved in preparation for pregnancy in marsupials to understand the importance of uterine changes in the evolution of amniote viviparity. Melanie's project makes a major contribution to our understanding of marsupial pregnancy as it is the first study of the specific uterine changes involved in preparation for attachment. Marsupials make an exciting contribution to evolutionary questions, and the project highlights many interesting areas for future research. The next step is to identify the major molecular changes required to produce the morphological changes in marsupials, and to determine whether these changes are consistent across viviparous amniote groups. Melanie has recently published her first paper in the high-ranking *Journal of Morphology*.

Ruth Wells (University of Sydney, School of Psychology)

Ruth Wells is enrolled in a doctorate of clinical psychology and Master of Science at the University of Sydney. With an exceptional display of initiative, Ruth built relationships with psychologists, psychiatrists, academics and health workers in Jordan over the internet; crowd funded her travel costs, and then completed the research project in Jordan where she explored barriers to mental health care for Syrian refugees living in Jordan. Planned research in 2015 will involve community members, including both psychologists and lay people, in the administration and evaluation of the program Ruth and her team have developed to train Syrian staff and volunteers to run group treatment programs.

Stephen Parker (University of New South Wales, School of Chemistry)

Stephen Parker is in his final year of a PhD in the Nanomaterials group in the School of Chemistry, UNSW, where he is making surfaces that can capture cells from a blood sample and then release a single targeted cell that has a particular characteristic. This is achieved using innovative surface chemistry that has an electrochemically-cleavable group in it. Stephen has combined his discovery with technology from the group that allows the electrochemistry to be directed to specific locations on the surface. The research is directed at circulating tumour cells which provide a potentially accessible biomarker for detection, characterisation and monitoring the progression of non-haematological cancers.

Linh Tran (University of Wollongong, Centre for Medical Radiation Physics (CMRP))

Linh Tran is a third-year PhD student at Centre for Medical Radiation Physics (CMRP), University of Wollongong, Australia. Linh's research field involves development of innovative semiconductor detectors for dosimetry and microdosimetry in radiation protection and radiation therapy applications and their radiation hardness. She was a major contributor in development and study of large area alpha particle silicon cleanable detector for in-field measurement of soil radioactive contamination and new generation of 3D silicon microdosimeters mimicking human biological cells and used for measuring dose equivalent in mixed radiation field relevant to the space radiation environment as well as in heavy ion therapy. Linh received Master Degree in Physics in 2008 from Dubna University in Russia. She then has started her professional career in Vietnam Atomic Energy Institute and has worked as researcher in radiation protection for 3 years before coming to Australia as a PhD student. Linh has been awarded with a full scholarship for her studies in Russia and in Australia. She is now very much enjoyed doing research with CMRP team at University of Wollongong and she hopes that innovative radiation measurements devices will be available soon for improvement of human quality of life. She won the Jak Kelly prize through her presentation on the "Development of 3D semiconductor microdosimetric sensors for RBE determination in ^{12}C heavy ion therapy" at a joint meeting of the RSNSW and Australian Institute of Physics as part of the AIP's annual postgraduate awards meeting, held at the University of Sydney on 18 November, 2014.

The Jak Kelly Award winner also presented at the Society's meeting on 3 December. The other three winners will be invited to make a presentation on their work at the first Society's first meeting in 2015, to be held in Sydney on 4 February, 2015.



Archibald Liversidge: Imperial Science under the Southern Cross

Roy MacLeod

Royal Society of New South Wales, in association with Sydney University Press
ISBN 9781-9208-9880-9

When Archibald Liversidge first arrived at the University of Sydney in 1872 as Reader in Geology and Assistant in the Laboratory, he had about ten students and two rooms in the main building. In 1874, he became Professor of Geology And Mineralogy and by 1879 he had persuaded the University Senate to open a Faculty of Science. He became its first Dean in 1882.

In 1880, he visited Europe as a trustee of the Australian Museum and his report helped to establish the Industrial, Technological and Sanitary Museum which formed the basis of the present Powerhouse Museum's collection. Liversidge also played a major role in establishing the *Australasian Association for the Advancement of Science* which held its first congress in 1888.

This book is essential reading for those interested in the development of science in colonial Australia, particularly the fields of crystallography, mineral chemistry, chemical geology and strategic minerals policy.

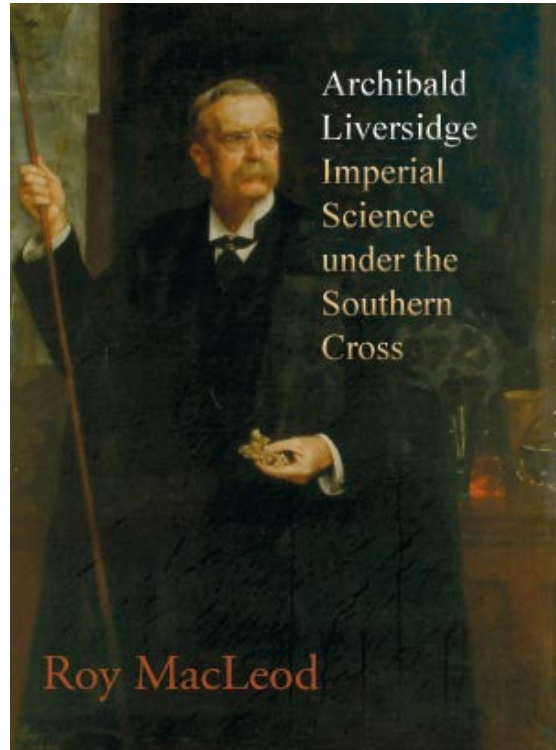

To order your copy, please complete the form Liversidge Book Order Form available at: http://royalsoc.org.au/publications/books/McLeod_Liversidge_Order_Form.pdf and return it together with your payment to:

The Royal Society of NSW,
(Liversidge Book),
121 Darlington Road,
Darlington NSW 2006,
AUSTRALIA

or contact the Society:

Phone: +61 2 9036 5282
Fax: +61 2 9036 5309
Email: info@royalsoc.org.au

The Royal Society of New South Wales



INFORMATION FOR AUTHORS

Details of submission guidelines can be found in the on-line Style Guide for Authors at:
http://royalsoc.org.au/publications/author_info.htm.

Manuscripts are only accepted in digital format and should be e-mailed to: editor@royalsoc.org.au

The templates available on the Journal website should be used for preparing manuscripts. Full instructions for preparing submissions are also given on the website.

If the file-size is too large to email it should be placed on a CD-ROM or other digital media and posted to:

The Honorary Secretary (Editorial),
The Royal Society of New South Wales,
PO Box 576,
Crows Nest
NSW 1585
Australia

Manuscripts will be reviewed by the Editor, in consultation with the Editorial Board, to decide whether the paper will be considered for publication in the Journal. Manuscripts are subjected to peer review by at least one independent reviewer. In the event of initial rejection, manuscripts may be sent to other reviewers.

Papers (other than those specially invited by the Editorial Board) will only be considered if the content is either substantially new material that has not been published previously, or is a review of a major research programme. In the case of papers presenting new research, the author must certify that the material has not been submitted concurrently elsewhere nor is likely to be published elsewhere in substantially the same form. In the case of papers reviewing a major research programme, the author must certify that the material has not been published substantially in the same form elsewhere and that permission for the Society to publish has been granted by all copyright holders. Letters to the Editor, Discourses and short notes, and abstracts of Australian PhD theses may also be submitted for publication.

The Society does not require authors to transfer the copyright of their manuscript to the Society but authors are required to grant the Society an unrestricted licence to reproduce in any form manuscripts accepted for publication in the Journal and Proceedings. Enquiries relating to copyright or reproduction of an article should be directed to the author.



CONTENTS

Burton, Michael	Editorial	90
INVITED DISCOURSES		
David Wilson	Just a little Analysis.... (Awarded RSNSW Edgeworth David Medal, 2013)	91
Bruce Henry	An Applied Mathematician's Apology	94
REFEREED PAPERS		
Brien Holden, Stephen	The Evolution of Uncorrected Refraction Error as a Major Public Health Issue	101
Davis, Monica Jong, Serge Resnikoff	(Awarded RSNSW James Cook Medal, 2013)	
Brett Gooden	Segmentation and Oxygen Diffusion in the Ediacaran <i>Dickinsonia</i> : an Applied Analysis	107
John Page	Engineering Simulation – Frontier to a new Capability	121
John Nichols	A Precision and Bias Study of Four Masonry Flexural Stress Bond Wrenches	132
OBITUARY		
David Branagan	Dr Daniel John O'Connor	144
ERRATUM		
David Branagan	The Russian Expedition's Sydney Visit in 1820 and some Forgotten Blue Mountains Names (2010, V143, p1)	146
PROCEEDINGS	The 2014 Program of Events of the RSNSW	147
AWARDS	The Royal Society of New South Wales Awards for 2014: Clarke Medal, Edgeworth David Medal, James Cook Medal, RSNSW Scholarships, Jak Kelly Award	158
INFORMATION FOR AUTHORS		Inside Back Cover

The Royal Society of New South Wales
PO Box 576
Crows Nest NSW 1585 Australia

Web: www.royalsoc.org.au
www.facebook.com/royalsoc

E-mail: info@royalsoc.org.au (general)
editor@royalsoc.org.au (editorial)



Published December 2014